

Ames 4001SS & 5001SS 3 – 6”

REMOVING CAM-CHECKS

Place yourself so that the water flow through the valve is left to right.

1. Shut down water system and lock out system if possible. Slowly open all ball valves to relieve air and water pressure. After pressure is relieved, loosen bolts on groove coupler and remove groove coupler and cover plate from valve body.
2. Remove #1 Cam-check Assembly. **Do not use Cam Arm as a handle to unscrew Cam-Check.** Insert lid bolts in 1st check seat ring (see fig. 1), insert a long screwdriver or pry bar between lid bolts. Gently apply pressure against the bolts and turn seat assembly counter clockwise moving bolts hole to hole to maintain turning leverage (two additional bolts will eliminate need to move lid bolts from hole to hole). Finish unscrewing by hand and remove through top access port. Unscrew #2 Cam-Check (turn counter-clock wise) by placing a long screwdriver across lid bolts inserted in holes located in the 2nd check seat ring, similar in method used to remove 1st check and applying pressure to loosen #2 Cam-Check. Finish unscrewing by hand.
3. To clean Cam-Check, locate the Cam Arm opening stud on the outlet flange of the valve assembly. Slide the Cam Arm over the stud with the check threads facing downward (fig. 2). Tighten a 1/4” nut on stud to secure cam bar. Slowly pull the assembly outward to open check allowing exposure of the seat and clapper contact area for cleaning. The assembly may be locked open by aligning the holes in the cam bar and hinge arms and inserting a rod (fig. 4).

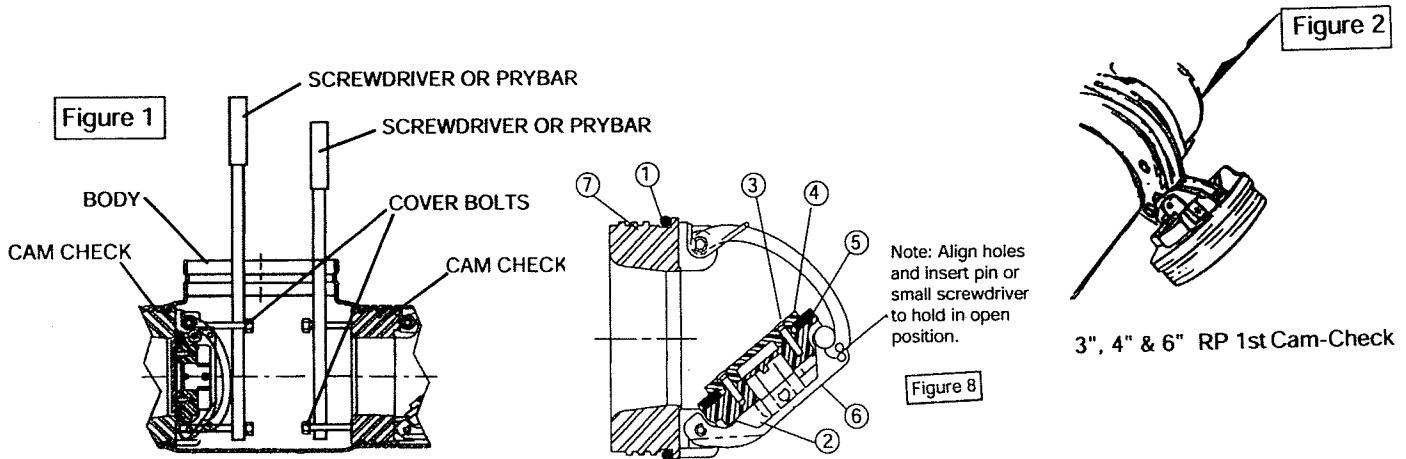

CAM-CHECK DISASSEMBLY

Please use caution when disassembling cam-check.

The cam-check is a spring-loaded mechanical device. Failure to do so may result in potential injury.

FIGURE 3

Press down on the check assembly to unload the cambar from hinge arms and roller. Then place a thin rod into a maintenance hole in one hinge arm.

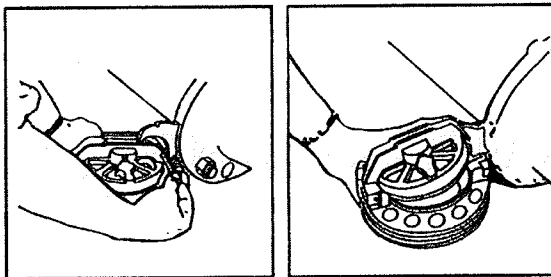

FIGURE 4

Using your free hand, swing the clapper assembly away from the seat. Align (A) lockout holes.

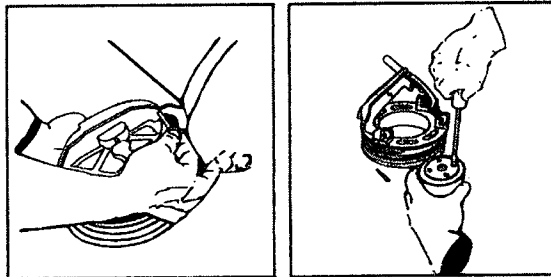

FIGURE 5

Remove 1 c-clip from the center pivot pin. Withdraw the center pivot pin from the clapper and the hinge arms. Remove the clapper assembly from the check assembly module. **Note: You may replace this item as an assembly or you may continue and replace only the sealing disc.**

FIGURE 6

Disassemble the clapper by removing 4 screws, disc retainer and the clapper disc. Disc may be flipped if sealing surface is damaged.

Before reinstallation of check assembly, thoroughly clean O-ring groove and lubricate O-ring with F.D.A. approved lubricant.