

MAINTENANCE INSTRUCTIONS:

Ames backflow prevention assemblies require minimum maintenance. Maintenance on all internal components can be performed without removal of the assembly from line service. All assemblies must be retested once maintenance has been performed.

Removing and Installing Knuckle Joint Assembly 2000 DCA & 3000 DCDA

1. Shut down water system and lockout system if possible.
2. Slowly open test cocks or air bleed screw to relieve pressure.
3. Remove all cover plate bolts, lid and cover plate gasket from valve body.
4. Push retainer clip into knuckle joint retention openings located on inner and outer linkages of knuckle joint assembly, until clapper opens slightly. (Drawing 1).
5. Carefully loosen and remove the two knuckle joint mounting bolts, located on exterior of valve body.
6. Remove knuckle joint assembly from body assuring retainer clip is not disturbed.
7. Bolt the knuckle joint assembly on the exterior of the body through the mounting link holes (Drawing II), or press on hard surface to remove retainer clip.
8. Push on clapper plate to release retainer clip, and remove clip. Slowly remove tension on clapper and unbolt knuckle joint assembly from mounting link holes.

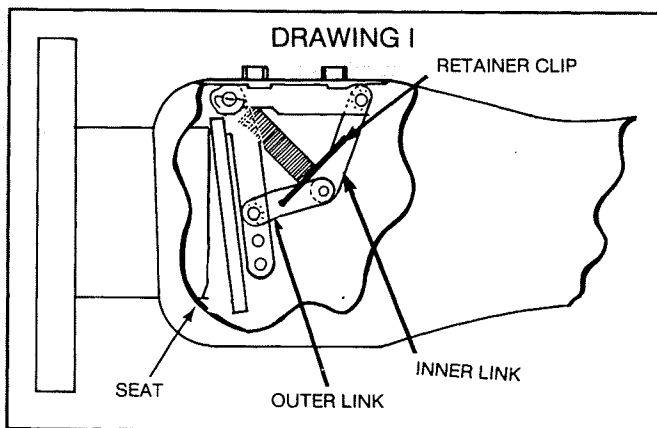

9. Bolt replacement knuckle joint assembly as in step 7.
10. Push on clapper plate to extend springs and install retainer clip. Unbolt knuckle joint assembly from mounting link holes.
11. Insert two New $\frac{3}{8}$ x 1" sealed mounting bolts through mounting holes in body. Position knuckle joint in place inside body, and finger tighten both bolts.

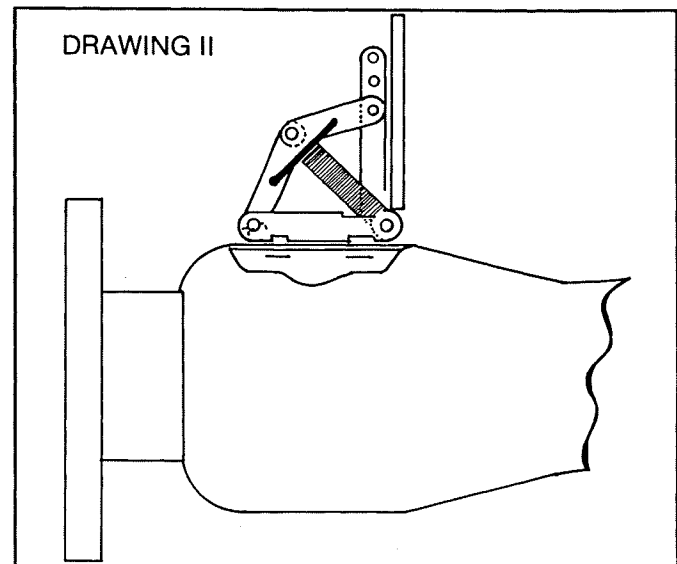

12. Torque knuckle joint mounting bolts to approximately 10 FT LBS.
13. Remove retainer clip.
14. Install new gasket with lid. Torque lid bolts to 120 FT LBS.

Removing And Installing Knuckle Joint Assembly (#1 check valve on 4000 RP, 1st and 2nd check on 10" 2000 DC & 3000 DCDC).

1. Depressurize assembly.
2. Remove all cover plate bolts, cover and gasket from #1 check.
3. Locate pivot arm of tong tool onto horizontal link pin of knuckle joint (Drawing III).
4. Locate pivot arm of tong tool into adjacent port flange hole.

5. Remove the two rear mounting **nuts** from exterior of body.

6. While depressing tong tool handle, work rear mounting link away from port tube. (Caution: considerable tension is on tong tool hold firmly).

7. Slowly release controlled pressure on tong tool handle until tension is relieved from springs.

8. Remove tong tool from device.

9. Remove 2 - $\frac{3}{8}$ " mounting **bolts** from front of body.

10. Remove knuckle joint assembly from body.

11. Reinstall new knuckle joint assembly by reversing above procedure.

DRAWING III

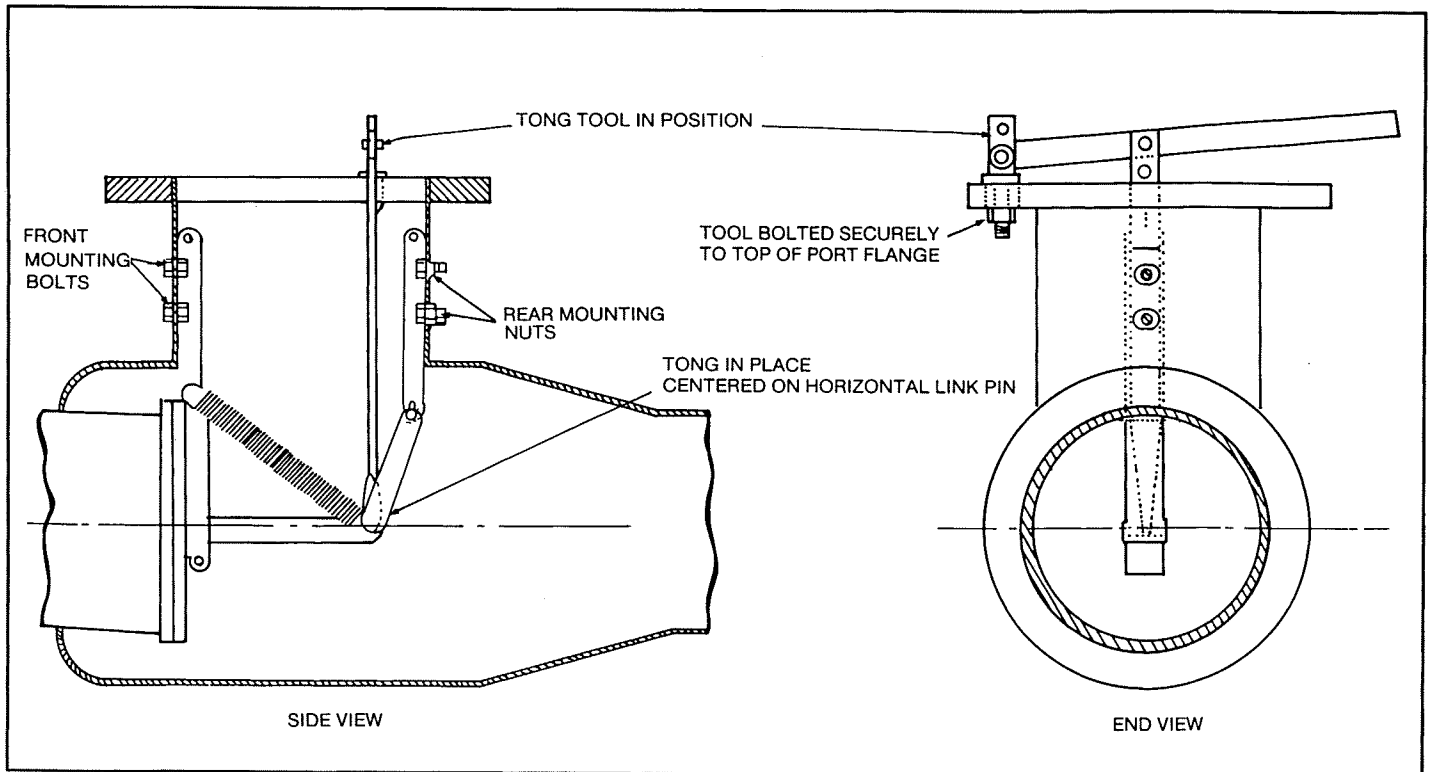

REMOVAL AND REPAIR OF RELIEF VALVE 4000 / RP 5000

1. Depressurize assembly Disconnect hose and remove relief valve from elbow flange. Inspect rubber relief valve mounting seat gasket for debris, cutting or distortion of rubber. Remove 5/16" lid bolts.

2. Disassemble piston assembly by unscrewing top diaphragm plate from seat tube in counter clockwise direction. Remove o-ring from relief valve body. Clean and inspect all parts for damage, debris or buildup. Clean and inspect vent hole in seat tube and o-ring groove in body.

3. Place small amount of FDA approved lubricant on o-ring groove, seat tube OD, o-ring guide pin and diaphragm plate threads. (Do not use petroleum or solvent based lubricant). Clean o-ring groove on top washer plate. Hold top washer plate with threaded side up. Set diaphragm on washer plate with side marked HIGH PRESSURE SIDE down, install bottom washer plate with spring guide shoulder away from diaphragm.

Set seat tube on threaded stub of washer plate and slowly engage threads. **Hand tighten** seat tube in clockwise direction.

4. Stretch to 3" diameter and lubricate o-ring and place in o-ring groove. Place relief valve spring in body. Place lid with bolts on piston assembly and thread diaphragm over bolts. Insure that diaphragm is not pinched between lid and washer plate. Reassemble unit assuring spring is seated over guide and that tube is carefully pushed through o-ring in body. Hand tighten bolts. If o-ring has been pushed from groove, disassemble, inspect for damage, and repeat assembly.

Clean and place rubber seat mounting gasket in recess with raised o-ring side out. Before installing relief valve, slightly open #1 gate valve to insure hose is free of debris and debris is washed from main body. Bolt relief valve to mainline valve and install hose. Open #1 gate valve and bleed air from all test cocks and air vents on relief valve.

5. Test assembly.

MAINTENANCE INSTRUCTIONS: Check Seat Replacement

I. Removing Bronze Seat (all assemblies except #1 RP, 8" & 10" DC & DCDC)

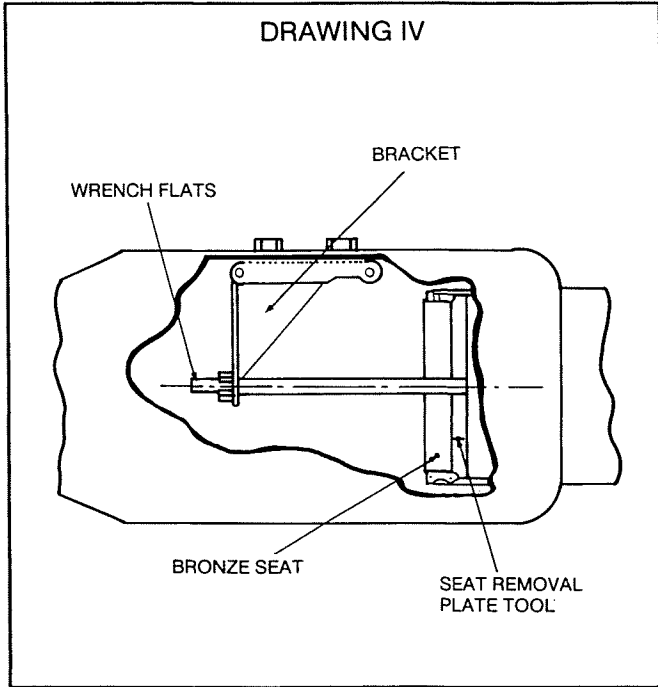

1. Remove knuckle joint assembly.
2. Insert seat replacement bracket into interior of body and install where knuckle joint was located.
3. Place seat removal tool beyond seat into pulling position.
4. Install rod through bracket seat and thread into seat removal tool.
5. Thread nut and washer onto rod until contact with bracket.
6. Place wrench on rod flats, while using another wrench to tighten nut until seat dislodges from body.
7. Remove seat and all tooling except bracket from body.

Installing New Bronze Seat (Drawing V)

1. Clean debris from seat area.
2. Lubricate seat area with water soluble FDA approved lubricant.
3. Install tooling as per Drawing V.
4. Using two crescent wrenches, tighten nuts on rod in opposite directions until seat, with o-ring, is securely into place. Visually inspect seat to insure contact with body.
5. Remove tooling.
6. Install knuckle joint and lid.

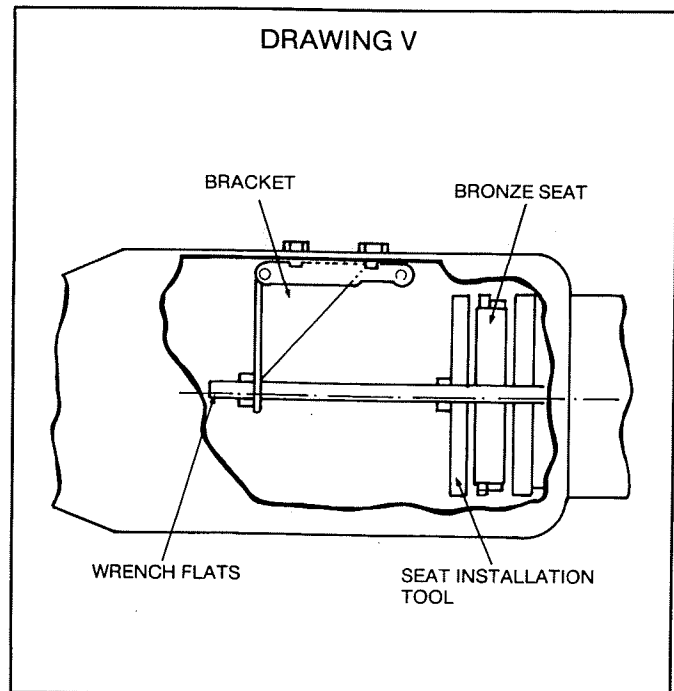

II. Removing and Installing bronze seat (1st check 4000 RP and 8" & 10" DC & DCDC) Drawing VI

Note: Procedure is identical to previous removal and installation of seat.

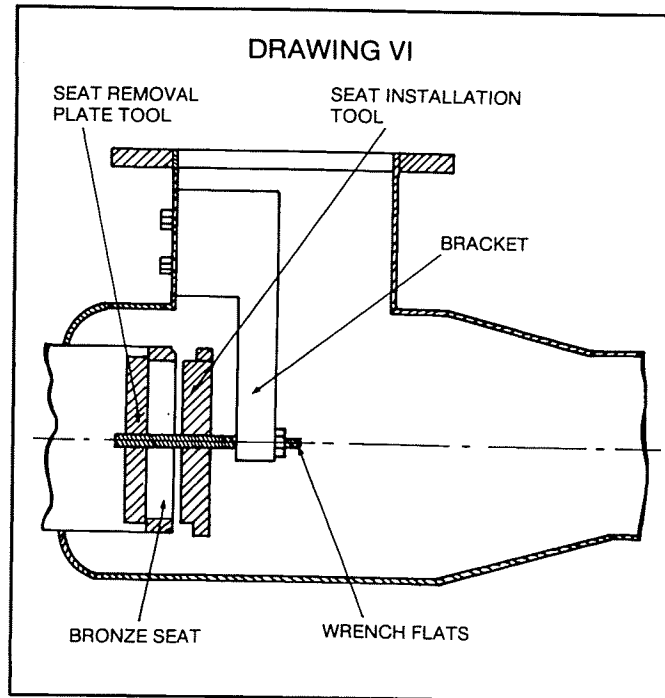

AIR GAP DRAIN 4000 5000

APPLICATION

The Air Gap Drain is designed to be installed under the relief valve on Ames RP and RPDA devices to catch minor relief valve discharges created by pressure fluctuations of the supply line. The Ames Air Gap Drain is approved by the USC FCCCHR.

INSTALLATION INSTRUCTIONS:

- A. Before installation, check with local authorities as an air gap drain is not approved for all installations.
- B. Remove lower two relief valve mounting bolts.
- C. Align bolt holes on air gap drain with holes in relief valve flange.
- D. Insert the two bolts which were removed in Step B through air gap drain and relief valve flange, then tighten.

