

Check Maintenance Instructions
C200-C300-C400-C500 & C200A-C300A 2 1/2-6"
M200-M300-M400-M500 & M200A-M300A 2 1/2-4"

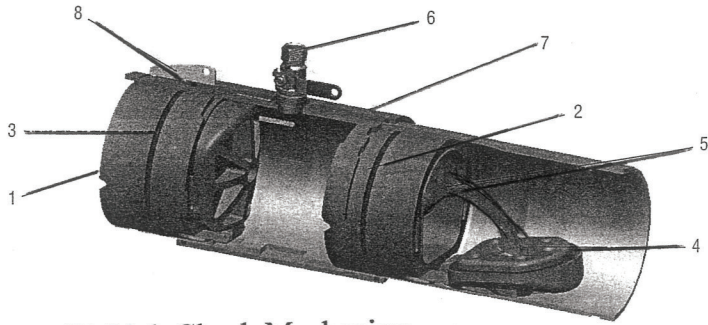

Bi-Link Check Mechanism

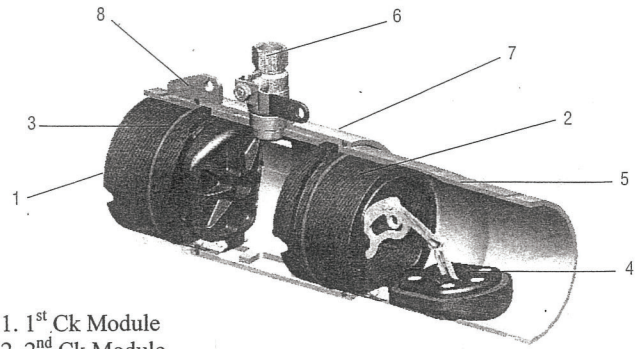

Tri-Link Check Mechanism

1. 1st Ck Module
2. 2nd Ck Module
3. Ck Module O-ring
4. Ck Disc
5. Clevis Pin Clip
6. Sleeve Test Cock
7. Sleeve
8. Sleeve O-ring

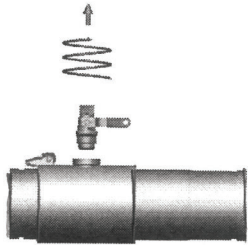

Figure A

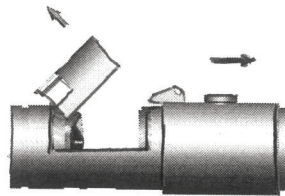

Figure B

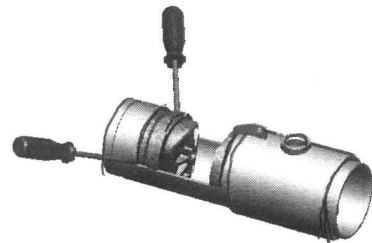

Figure C

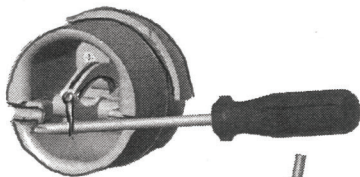

Figure D

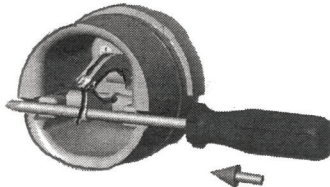

Figure E

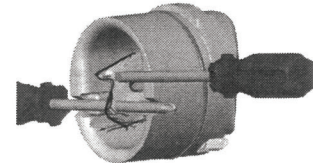

Figure F

Instructions

Prior to servicing any Ames valve, it is mandatory to shut down the water system by closing both the inlet and outlet shutoff valves. After shutoff valves are closed, open test cock #2, #3 & #4 to relieve pressure within the backflow assembly.

1. After #3 test cock has been opened to relieve pressure, remove #3 test cock from housing. (Figure A)
2. Insert a #3 screwdriver through the hole on the top of the cover sleeve and using both hands rotate the cover sleeve approximately 1/4-turn clockwise and 1/4-turn counter-clockwise to break the sleeve O-ring seals. Using the screwdriver, slowly slide the cover sleeve to the downstream side of the housing. (Figure B)
3. Remove the stainless steel check retainer from the housing. (Figure B)
4. Remove the #1 check module (Figure C) by inserting two flat blade screwdrivers into the slots on either side of the check module and gently pry the check module toward the open zone.

6. To clean or inspect either check module, insert a #3 screwdriver through the downstream side of the check module as shown in Figure D & E. When the screwdriver is in place, remove the "E"-clip (Figure F) and pin connecting the structural members and the check clapper will open with no tension.
7. Thoroughly clean the seating area. The sealing disc may be removed, if necessary, by removing the screws connecting the keeper plate to the clapper. The sealing disc may be reversed and reinstalled if the elastomer is cut or damaged.
8. Wash check module and O-ring and inspect for any damage. If damaged, reinstall new parts.
9. After thorough cleaning, lubricate O-ring w/FDA approved lubricant, replace pin and "E"-clip in structural members, remove screw driver and reinstall check modules and assemble housing in reverse order of these instructions.

Check Maintenance Instructions

C200-C300-C400-C500 8-10"

M200-M300-M400-M500 6-10"

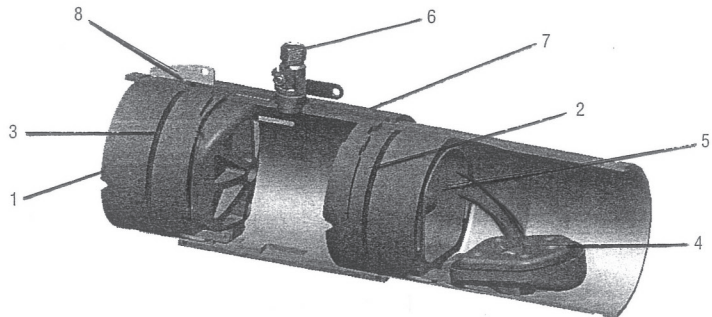

Bi-Link Check Mechanism

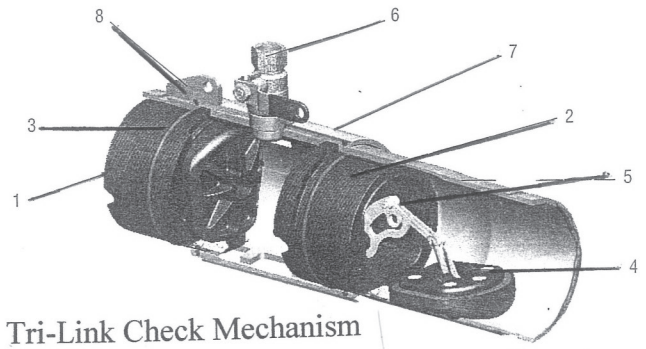

Tri-Link Check Mechanism

- 1. 1st Ck Module
- 2. 2nd Ck Module
- 3. Ck Module O'ring
- 4. Ck Disc
- 5. Clevis Pin Clip
- 6. Sleeve Test Cock
- 7. Sleeve
- 8. Sleeve O'ring

Material/Tool Requirements:

- #4 Phillips screwdriver or 3/8" diameter rod, length sufficient to span diameter of check, see Figures A and B.
- 1/2 - 13 x 5" fully threaded hex bolt (Service bolt).
- 3/4" open end or socket wrench.

Figure A

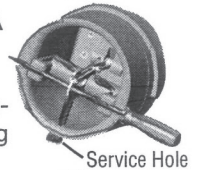

Instructions:

Prior to servicing any Ames valve, it is mandatory to shut down the water system by closing both the inlet and outlet shutoff valves. After shutoff valves are closed, open test cock #2, #3 & #4 to relieve pressure within the backflow assembly.

1. After #3 test cock has been opened to relieve pressure, remove #3 test cock from housing.
- When repairing a 6," 8" or 10" (150, 200, 250mm) assembly, remove both Victaulic couplers from body. Slide the downstream Victaulic coupler gasket to the downstream side of the housing. The upstream Victaulic coupler gasket stays in place.

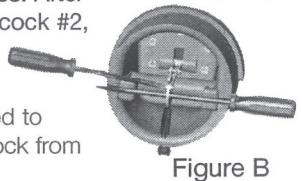

Figure B

2. Remove check/s to be maintained.
3. Locate the service hole and thread in the service bolt by hand until it contacts the linkage. (Figure A)
4. Continue to thread in service bolt with the wrench until the service hole in the linkage is aligned with the service notches on the spring arbors. (Figure A)
5. Insert the Phillips screwdriver through the arbors and service hole of the linkage making sure that the tip of the screwdriver extends past the ends of the arbors by a minimum of 1/4" (6mm). (Figure B)
6. Back out the service bolt until load is transferred to the screwdriver. Continue to back out the service bolt until sufficient clearance is achieved to remove the complete spring mechanism.
7. To disconnect linkage, remove retaining clip and pin (store in a safe location for reinstallation).
8. To remove spring mechanism, grasp the screwdriver at the center and pull complete assembly straight out and store in a safe place.
9. Reinstall in reverse.

WARNING - While the spring mechanism is removed for check servicing; never pull the screwdriver out or off the support notches on the arbors. Doing so may cause bodily injuries.

Relief Valve Maintenance C400-C500-M400-M500 2 1/2-10"

Servicing Relief Valve

Prior to servicing the relief valve, it is mandatory to shut down water system by closing both the inlet and outlet shutoff valves and relieving pressure within the assembly by opening the #2, #3 and #4 test cocks.

DO NOT REMOVE SPIDER BUSHING FOR SERVICING.

1. Disconnect the hose from the bottom cover plate to the relief valve.
2. An O-ring seals the relief valve body to the main housing. It is not necessary to tighten the connection beyond firm hand tightening. The relief valve should be able to be removed by hand untightening. Unscrew the relief valve from the housing.
3. Remove the cover plate of the relief valve by removing the four connecting screws.
4. Remove the rubber diaphragm from the relief valve. Be aware of how the diaphragm is configured so that it can be reinstalled in the same manner. The hard rubber tab in the diaphragm fits into a similar socket in the head of the piston. (Figure 1)
5. Hold the relief valve in both hands with the threaded end up and both thumbs on the head of the piston. Push up on the piston until the piston shaft with the attached E-clip is exposed. Remove the E-clip (Figure 2)
6. Remove the piston and spring from the relief valve housing and thoroughly clean all parts including the diaphragm. Inspect all rubber parts for damage and if damaged, replace them with new parts.
7. Reassemble the relief valve in the reverse order that it was disassembled.

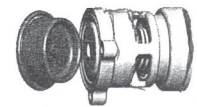

Figure 1

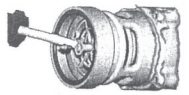
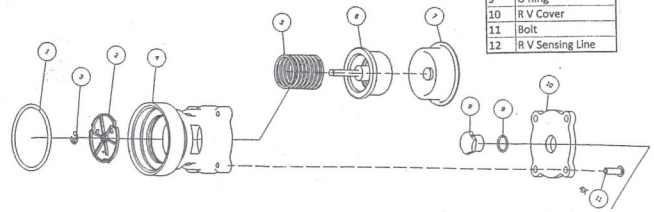

Figure 2



Item	Description
1	O'Ring
2	Spider Bearing
3	Retainer Clip
4	R V Body
5	R V Spring
6	R V Piston
7	Rolling Diaph
8	R V Fitting
9	O'Ring
10	R V Cover
11	Bolt
12	R V Sensing Line

