

# SERVICE PROCEDURES

Models 805Y, 805YD, 806, 806YD, 825, 825D, 825YD (2 1/2" - 3")

---

## 1. Check Valve Disassembly Model 825, 825D and 825YD (Sizes 2 1/2" - 3")

---

a. Slowly close outlet shut-off valve and inlet shut-off valve. Bleed residual pressure by opening #4, #3, and #2 testcocks.

b. Remove cover bolts uniformly while holding cover in place. Remove cover.

**CAUTION: Spring is retained in body by cover.**

c. Lift check assembly from body being careful not to damage internal epoxy coating.

d. If necessary, unthread bushing (item 4A) from cover.

---

## 2. Check Assembly Repair Models 825, 825D and 825YD (Sizes 2 1/2"-3")

---

a. Unthread nut on stem and remove disc washer and seat disc.

b. Inspect seat disc for wear or damage. Replace with new seat disc or turn used disc over if new disc is not available.

**NOTE: The discs are symmetrical. It is usually possible to turn the disc over and obtain an effective seal.**

c. If the seat disc has been severely cut along the seat disc ring diameter, the assembly is being subjected to extremely high back pressure from thermal water expansion, water hammer, or other causes of excessive water pressure. A disc damaged in such a manner should be replaced and not turned over to be re-used.

---

## 3a. Valve Seat Removal (Sizes 2 1/2"-3") Threaded-in Seat Ring Type Models Model 825

---

1. Remove seat ring by unthreading in counter-clockwise direction being careful not to damage the internal epoxy coating in valve. A tool to aid in this process is available.

2. Remove bushing and bushing nut (item 2A & 2B).

3. Remove o-ring.

---

## 3b. Valve Seat Removal (Sizes 2 1/2"-3") Bolted in Seat Ring Type Models Models 825D & 825YD

---

1. Remove the three capscrews and washers retaining the seat ring.

2. Pull the seat ring from the valve body being careful not to damage the internal epoxy coating of valve.

3. If necessary, unthread the bushing (item 2A) from the seat ring.

4. Remove the o-ring.

---

## 4a. Valve Seat Reassembly (Sizes 2 1/2"-3") Threaded-in Seat Ring Type Models Model 825

---

1. Lubricate o-ring with FDA approved lubricant and replace on seat ring.

2. Reinsert bushing into seat ring center.

3. Thread seat ring into valve body in clockwise direction being careful not to damage the internal epoxy coating of valve.

---

## 4b. Valve Seat Reassembly (Sizes 2 1/2"-3") Bolted-in Seat Ring Type Models Model 825D & 825YD

---

1. Lubricate o-ring with FDA approved lubricant and replace in seat ring.

2. Thread bushing into seat ring.

3. Place the seat ring carefully into body and retain with three capscrews and washers being careful not to damage the internal epoxy coating of valve.

---

## 5. Check Valve Reassembly (Sizes 2 1/2"-3")

---

a. Position the disc in the cleaned holder and retain with disc washer. Insert stem into disc holder, replace the nut on stem and tighten.

**NOTE: On older Model 825 valves, the disc holder is sealed to the stem with a sealant. If the seal is broken, the stem and holder must be cleaned and new sealant applied. Newer valves, Models 825D and 825YD, use an o-ring so a sealant is not required.**

b. Thread bushing into cover.

# SERVICE PROCEDURES

## 805Y, 805YD, 806, 806YD, 825, 825D, 825YD

c. Carefully place stem of check assembly into seat ring bushing. Replace spring centering diameter on the disc washer. **NOTE: Be sure the heavier spring (6 PSI) is placed in first check and lighter spring (2 PSI) is placed in second check or the unit will not operate properly and discharge from the relief valve could occur.** The wire diameter is visibly thicker on the heavier spring and thinner on the lighter spring. Care should be taken to avoid damaging internal epoxy coating of valve.

d. Place cover on check body securing spring and stem into cover.

e. Bolt cover onto check body while holding cover in place with appropriate hand force. Spring will be retained in body by cover.

f. Slowly open inlet shut-off valve. Bleed air from valve by opening first the #4 testcock, then the #3, #2 and #1 testcocks and air bleeds on all covers.

g. Slowly open outlet shut-off valve and return the valve to service.

h. Test the assembly to insure it is operating properly.

**(4" - 10")**

### 1. Check Valve Disassembly (Sizes 4"-10")

a. Slowly close outlet gate valve then slowly close inlet gate valve. Bleed residual pressure by opening first the #4 testcock, then #3, and #2 testcocks.

b. Remove cover bolts and cover. Unscrew bolts uniformly to avoid binding of the cover. The spring will push the cover approximately 1/2 inch off the top of the valve body.

### 2. Seat Disc Removal (Sizes 4"-10")

**CAUTION: The newer model 825 cast iron units have threaded disc holders with four (4) cast lugs, (6 lugs on 10" assemblies), 1/2" high located on back side, outside the spring diameter. If the Model 825 you are servicing does not have these lugs, SPRING TENSION MUST BE RELEASED BY USING THE SPRING REMOVAL TOOL BEFORE FURTHER DISASSEMBLY. DO NOT ATTEMPT TO REMOVE SPRING TENSION ON OLDER MODEL 825'S WITHOUT THE USE OF THIS TOOL. SEE SPRING REMOVAL INSTRUCTIONS. Newer Models 825, 825D and 825YD assemblies have the disc holder threaded on the stem. Therefore, the seat disc can be removed without releasing spring tension on these newer models.**

a. Unthread retaining nut from stem and remove disc washer and seat disc.

b. Inspect seat disc for wear or damage. Replace with new seat disc or turn used disc over if new disc is not available.

**NOTE: The discs are symmetrical. It is usually possible to turn the disc over and obtain an effective seal.**

c. If the seat disc has been severely cut along the seat disc ring diameter, the assembly is being subjected to extremely high back pressure from thermal water expansion, water hammer, or other causes of excessive water pressure. A seat disc damaged in this manner should be replaced and not turned over for re-use.

d. Remove disc holder from stem.

**NOTE: On older Model 825 valves, the disc holder is sealed to the stem with a sealant. If the seal is broken, the stem and holder must be cleaned and new sealant applied. Newer valves, Models 825D and 825YD use an o-ring so a sealant is not required.**

### 3. Spring Removal (Sizes 4"-10")

**CAUTION: TO AVOID POSSIBLE INJURY, DO NOT ATTEMPT TO REMOVE SPRING TENSION WITHOUT THE USE OF THE SPRING REMOVAL TOOL.**

**ON OLDER MODEL 825 VALVES, IT IS NECESSARY TO REMOVE THE SPRING BEFORE THE RUBBER SEAT DISC CAN BE REMOVED.**

a. Leave check assembly in body.

b. Install long studs in body 180 degrees apart.

# SERVICE PROCEDURES

Models 805Y, 805YD, 806, 806YD, 825, 825D, 825YD

c. Place spring removal tool over stud and retain with nuts.

d. Unthread capscrew (Item 7A) using 9/16" hex socket.

e. Release spring tension by unthreading nuts on long studs. Use alternating turns to keep tool parallel to valve body.

f. Remove spring guide and stem assembly.

g. Remove guide bushing by unthreading.

---

## 4a. Valve Seat Removal (Sizes 4"-10") Threaded-in Seat Ring Type Model 825

---

1. Remove check valve as described above.

2. Remove seat ring by unthreading in the counter-clockwise direction.

3. Remove bushing and bushing nut if used (bushing and nut is used on older Model 825).

4. Remove o-ring.

---

## 4b. Valve Seat Removal (Sizes 4"-10") Bolted in Seat Ring Type Model 825D or 825YD

---

1. Remove check valve as described above.

2. Remove the three capscrews and washers retaining the seat ring.

3. Pull the seat ring from the valve body.

4. Unthread the bushing (Item 2A) from the seat ring.

5. Remove the o-ring.

---

## 5a. Valve Seat Reassembly (Sizes 4"-10") Threaded-in Seat Ring Type Models Model 825

---

1. Lubricate o-ring with FDA approved lubricant. Reposition the o-ring in the seat ring groove.

2. Replace the bushing and bushing nut (if used) in the seat ring (the bushing and nut is used on older Model 825).

3. Thread the seat ring into the seating area in a clockwise direction. Be careful not to damage internal epoxy coated surfaces.

---

## 5b. Valve Seat Reassembly (Sizes 4"-10") Bolted-in Seat Ring Type Models Models 825D & 825YD

---

1. Lubricate o-ring with FDA approved lubricant. Reposition the o-ring in the seat ring groove.

2. Thread the bushing into the seat ring.

3. Place the seat ring carefully into the valve body and retain with three capscrews and washers being careful not to damage the internal epoxy coated surfaces.

---

## 6. Check Valve Reassembly Models 825, 825D, and 825YD

---

a. Use reverse procedure for assembly.

b. Make sure the o-ring is properly placed in the groove. Do not force the cover into the body.

c. Do not damage epoxy coated surfaces.

d. Test unit to insure proper operation.

# SERVICE PROCEDURES

## RELIEF VALVE

### MODELS 825, 825D

---

## 1a. Relief Valve Disassembly Non-Modular Type Relief Valve Models 825 & 825D

---

1. Remove copper tubing from relief valve body.

2. Unthread the relief valve completely from the check valve body, leaving the seat ring in the check valve body. NOTE: If the seat ring is removed with the relief valve, the seat ring must be unthreaded from the relief valve diaphragm plate, being careful not to damage the seat ring threads and seating surface.

3. Remove cover bolts and nuts, diaphragm cover and spacer from the relief valve assembly.

4. Turn the relief valve upside down, unthread screw (Item 35) using a 9/16 hex socket, and remove diaphragm assembly, spring button and spring.

5. Unthread screw (Item 48) and remove diaphragm washer and diaphragm from diaphragm button.

6. Push main stem out of bottom of relief valve body.

7. Remove o-ring from body.

# SERVICE PROCEDURES • RELIEF VALVE

## 825 825D 825YD

---

### 2a. Relief Valve Reassembly Non-Modular Type Relief Valve Model 825 and 825D

---

1. Assemble washer, outer diaphragm, spacer, diaphragm button, inner diaphragm and washer by securing with capscrews to form diaphragm assembly. When installing diaphragms, make sure side of diaphragm marked "button side" (fabric side) is toward diaphragm button and that diaphragm is not pinched.

2. Lubricate mainstem o-ring with FDA approved lubricant. Place seat disc on main stem and place disc washer on seat disc.

3. Slide main stem bolt through main stem assembly and place inside relief valve body cavity with main stem bolt protruding.

4. Position spring over bolt and fit diaphragm assembly over spring. Compress diaphragm assembly into spring until main stem bolt threads into diaphragm assembly. Secure using a torque wrench. **DO NOT TIGHTEN MAINSTEM BOLT BEYOND 15 INCH-LBS. OR DISTORTION OF THE MAIN STEM (ITEM 30) WILL**

#### OCCUR.

5. Thread seat ring into main valve body and thread relief valve into seat ring.

6. Reconnect copper tubing to relief valve.

7. Slowly open inlet shut-off valve and bleed air by opening first testcock #4, then testcocks #3, and #2 and all air bleeds.

8. Slowly open outlet shut-off valve and return the valve to service.

9. Test the assembly to insure it is operating properly.

---

### 3a. Relief Valve Seat Disc Replacement Modular Type Relief Valve Model 825YD

---

1. Disconnect sensing tubing. Remove relief valve cover (Item 21) by loosening cover bolts (Item 25) and remove the outer diaphragm (Item 26).

2. Grasp the relief valve button (Item 24) with one hand. Insert fingers into the rectangular relief valve port on the bottom of the relief valve and apply force to the seat disc. Pull the relief valve module straight out from the body. **DO NOT TWIST.**

3. Place the relief valve module on a flat surface. Holding the mainstem with one hand, loosen and remove the lower guide (Item 35) and disc washer (Item 33). Remove the rubber seat disc (Item 32) and turn over or replace as required. Inspect all parts and clean using clean water. Refer to section 5a on replacing relief valve diaphragms if this procedure is necessary.

4. Replace the disc washer and lower guide and tighten. Lubricate the o-ring (item 31a), with FDA approved lubricant. Insert the relief valve module into relief valve body, using your fingers to help guide the lower guide into the bushing (item 36a) on the relief valve seat ring. Push the module straight in. **DO NOT TWIST.**

5. If the relief valve module does not have a center label piece covering the screw (item 48), inspect the screw for burrs. If a burr is visible, remove or cover burr with a piece of flexible tape. This will protect the surface of the diaphragm.

6. Replace the diaphragm, placing the fabric side against the button. Work the rolled edge into the space between the module and the body making sure it is not pinched or buckled.

7. Replace the cover, tighten the cover bolts, and reconnect the sensing tubing. Return to service and test the assembly to insure proper operation.

---

### 4a. Relief Valve Seat Ring Replacement Modular Type Relief Valve Model 825YD

---

1. Disconnect sensing tubing. Loosen and remove the four mounting bolts (Item 38) from the adapter. Remove the relief valve.

2. Pull the seat ring (Item 36) out from the relief valve body and inspect for damage. Replace as required.

3. Reposition the relief valve to the adapter insuring the o-ring (item 36b) is properly positioned. Tighten the mounting bolts.

4. Reconnect the sensing tubing. Return to service and test the assembly to insure proper operation.

---

### 5a. Relief Valve Inner Diaphragm Replacement / Modular Type Relief Valve Model 825YD

---

1. Disconnect the sensing tubing. Remove the cover (Item 21) by loosening and removing cover bolts (Item 25).

2. Remove the outer diaphragm (Item 26). Grasp the relief valve button (Item 24) with one hand. Insert your fingers into the rectangular relief valve port on the bottom of the relief valve and apply force to the seat disc. Pull the relief valve module straight out **DO NOT TWIST.**

3. Remove the lower guide (item 35) and disc washer (item

33). Place the relief valve module upside down on a clean flat surface. Remove the center label piece protecting the screw head and save this piece for reassembly. With one hand apply force sufficient to hold the button against the mainstem. Keep the spring (item 28) compressed (spring is approximately 35 lbs.) while unscrewing the pan head screw (item 48). Remove the screw and relieve the spring tension. Remove the button and spring.

4. Remove the main stem and unthread the retainer (item 34) from the upper guide (Item 32). Remove the slip ring (item 27a) and inner diaphragm (item 27). Inspect, clean and replace parts as required.

5. To reassemble, position the bead on the inner diaphragm into the groove of the upper guide. Place the slip ring over the diaphragm. Lubricate the retainer threads using an FDA approved lubricant and thread the retainer onto the upper guide. Tighten to 60 inch-lbs. of torque.

6. Insert the mainstem into the diaphragm and "roll" the diaphragm into position by grasping the end of the diaphragm and mainstem with one hand and push the upper guide towards your other hand.

## 825YD

7. Test to make sure diaphragm is positioned properly by sliding the upper guide back and forth through the full travel. It must move freely and easily.

8. Once the inner diaphragm has been rolled, force the end of the mainstem snug against the end of the inner diaphragm. The screw hole in the end of the mainstem should be visible.

9. Replace the spring and button and tighten the screw while holding the button in place.

10. Make sure the screw (item 48) is free of burrs that may cut the outer diaphragm. Reposition the center label piece, that you have saved during disassembly, over the screwhead.

11. Replace the disc washer and lower guide insuring that the seat disc is clean and in position. Lubricate the upper guide o-ring (item 31a) using an FDA approved lubricant, to ease installation. **DO NOT USE LUBRICANT ON ANY OTHER PART.**

12. Position the relief valve module back into the body using your finger to help guide the lower guide into the relief valve seat ring bushing. Push the module straight in. **DO NOT TWIST.**

13. Replace the outer diaphragm, placing the fabric side against the button. Work the rolled edge into the space between the module and the body, making sure it is not pinched or buckled.

14. Replace the cover, tighten the cover bolts, and reconnect the sensing tubing. Return the valve to service and test to insure proper operation.

## CHECK SPRING REMOVAL TOOL

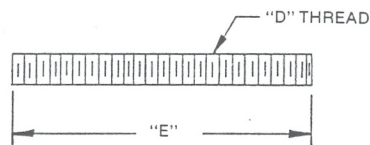
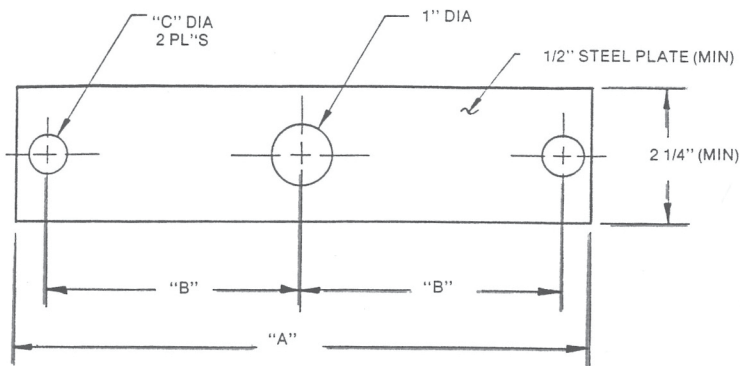

DIMENSIONS					
VALVE SIZE	A	B	C	D	E
4"	9 1/2	4 1/4	5/8	1/2-13	5 1/2
6"	12 1/2	5 5/8	3/4	5/8-11	5 1/2
8"	14 1/4	6 3/8	7/8	3/4-10	7
10"	16 1/2	7 1/2	7/8	3/4-10	7

**NOTE:** This information is provided to expedite servicing of FEBCO products. One tool may be fabricated for use on all required sizes by drilling all holes at appropriate dimensions in a single steel plate of maximum required length.

**CAUTION:** To avoid possible injury during use, do not fabricate tool from lesser strength material or to smaller dimensions than minimums shown.

## CHECK SEAT RING TOOL

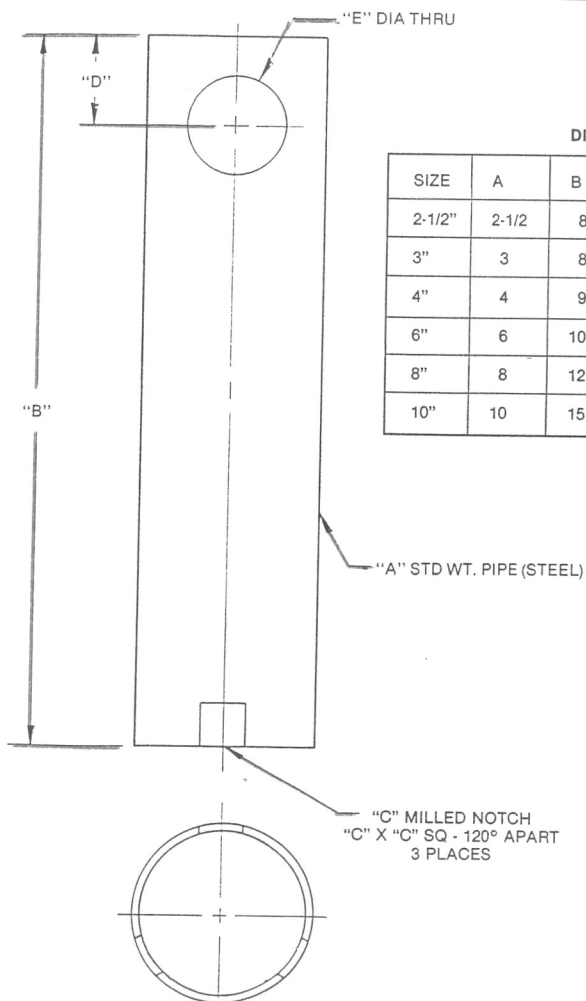

DIMENSIONS					
SIZE	A	B	C	D	E
2-1/2"	2-1/2	8	1/2	1	1
3"	3	8	1/5	1	1
4"	4	9	1/2	1	1
6"	6	10	5/8	1	1
8"	8	12	5/8	1	1
10"	10	15	5/8	1	1

## IS-F-825-DIAPH-SMALLRV INSTALLATION INSTRUCTIONS

### 825 YD, 860, 880, 880V

Relief Valve Sizes: 2 1/2" - 10" (65 - 250mm)

Proper installation of FEBCO Type 825 YD, 860, 880, 880V Relief Valve Inner Diaphragm into the Relief Valve Upper Guide

Failure to install inner diaphragm in this method will result in the inner diaphragm bursting after installation.

