

Model 850/850U 1/2" through 2"

CHECK MODULE DISASSEMBLY

1. Slowly close inlet and outlet ball valves. Bleed residual pressure by opening #2, #3, and #4 test cocks. Allow the test cocks to remain open until the reassembling is completed. Test cock #1 should remain closed.
2. Remove the cover bolts (item 21) using the appropriate size wrench.
3. Remove spacer (item 8) by grasping the flanged end of the spacer and pulling straight up.
4. Remove the inlet check assembly by pulling it in the direction of flow out from the body bore until it is completely exposed then lift out of the body.
5. Remove the outlet check assembly by placing the tip of a medium size flat nose screw driver in the slot of the seat (item 3) and prying the check assembly back until the red o-ring (item 3.1) is exposed. Then, using your fingers, pull it out from the body bore until it is completely exposed then lift out of the body.

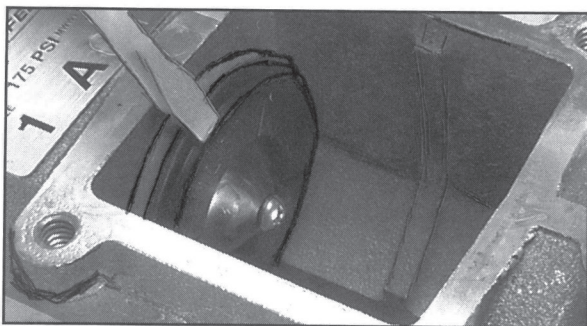

SEAL REPLACEMENT

Both check assemblies are disassembled and reassembled in the same manner. To service the checks you may replace the check modules with new ones by using check module assembly kits available from FEBCO. Or, you may also replace the rubber components in the check modules by using the replacement rubber parts kits available from FEBCO.

1. To disassemble, grasp the seat section (item 3) in one hand and the guide section (item 7) in the other hand and then rotate in a counter clock wise direction (approx. 1/8 turn) until the two parts disengage.

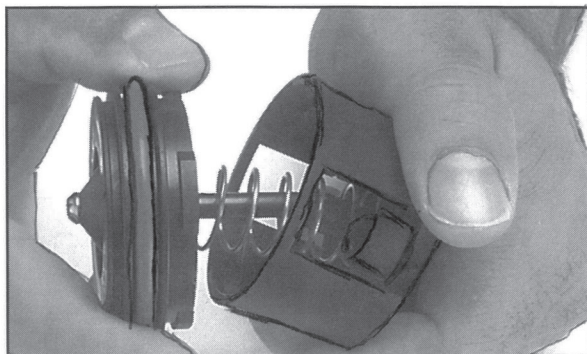

2. Remove retaining screw (item 5.2) and disc retainer (item 5.1) so the rubber disc is fully exposed. Carefully pry out the rubber disc from poppet. Be careful not to damage the poppet when removing the disc. Rinse poppet in clean water and replace the old rubber disc with new rubber disc. If the rubber disc is not damaged it can be reversed and reinstalled when a new disc is not available. Rinse all other internal components with clean water. Replace disc retainer and secure with retaining screw (item 5.2).

3. Reassemble check module in the reverse manner as indicated in above. When reassembling the check module be sure to insert the poppet stem into the guide hole and keep fingers clear of the slots in the module.

CHECK MODULE RE-ASSEMBLY

Use reverse procedure for assembly with the following special instructions.

1. Inspect the check module o-ring (item 3.1) for damage and replace if necessary. To ease assembly, apply a thin coating of FEBCO factory supplied petroleum jelly (food grade) to the o-ring (item 3.1) prior to installing in body. **CAUTION:** Excess lubricant may cause foreign debris to collect on internal components which could foul the check assembly and result in a test failure.
2. The word **INLET** is inscribed on the end of each module. That end should face the inlet of the valve.

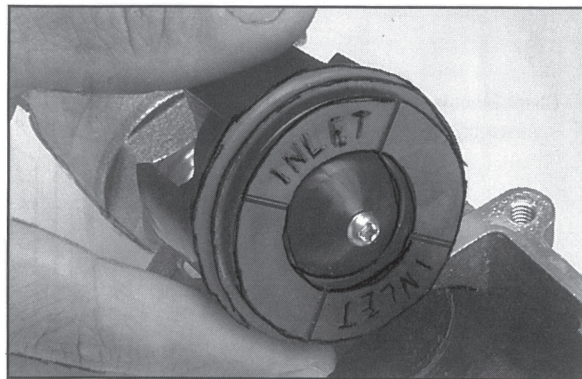

3. When replacing spacer (item 8) between the two check assemblies be sure that the flanged end of the spacer is touching the back side of the inlet check assembly so that the cover will fit properly. Next, replace cover making sure #3 test cock is on the upstream side. Do not over tighten cover bolts (Approximately 35 inch-pounds is sufficient).
4. After reassembling, close test cock #2, #3 and #4 (test cock #1 should already be closed), slowly open inlet ball valve. Bleed air from the unit by opening and closing test cock #2, then #3 and finally #4.
5. Check for external leaks and repair if necessary. Slowly open outlet ball valve.
6. Test assembly in accordance with the locally approved test methods.

CHECK VALVE DISASSEMBLY AND REASSEMBLY

1. SPRING MODULE REMOVAL

a. Slowly close outlet shut-off valve and inlet shut-off valve. Bleed residual pressure by opening #4, #3, and #2 test cocks

b. Remove cover bolts, removing the two bolts last that are located next to the retainer pin. Remove cover.

NOTE: Spring module is positioned in the body by the cover. Spring module is captured.

c. Remove pivot bearing (13) from the upper spring retainer of the spring module. Inspect pivot bearing (13) and bearing socket (15). Small hole in bearing socket indicates replacement is required. Remove retaining clip (5.1) from groove on one end of the load pin (7). Hold spring module with one hand while sliding out load pin (7) from arm (4). Lift out spring module and inspect for wear or damage. Replace spring module if necessary.

2. CHECK DISK REMOVAL

a. Remove jam nut (16) and washer (17) from check disc stem threads. Lift the arm and remove the check disc (6). Inspect sealing surface for debris or damage. Replace check disc if necessary.

NOTE: When jam nut (16) is tight, check disc is designed to "wobble."

3. SEAT RING ASSEMBLY REMOVAL

NOTE: Remove the seat ring assembly only if the seat ring (3) or arm (4) appear to be worn or damaged.

a. Remove locknuts (3.4) and washers (3.3) (see Figure No. 7).

NOTE: When reassembling, tighten locknuts to 12-15 ft/lbs. If leaking occurs around bolt, further tighten until leaking stops.

b. Remove seat ring assembly.

c. Remove retaining clip (5) from one end of the swing pin (4.2). Hold arm (4) while sliding out swing pin (4.2). Inspect bushings (4.1) and pin (4.2) for wear or damage. Replace if necessary. Inspect gasket (3.1) for debris and/or damage. Replace if necessary.

NOTE: Reverse the procedure above, to reassemble the components. Seat ring will only fit into body one way. Check alignment of seat ring if studs don't align with body holes. Gasket is also non-symmetric. Both seat ring and gasket have a notch that indicates non-symmetric hole. Clean all parts thoroughly with clean water before reassembly. Reassemble and bleed test cocks #4, and #3. Re-pressurize the assembly and test to ensure proper operation.

SEAT RING

FIGURE NO. 7

**Service
procedures
850, 856,
870, 870V,
876 and 876V
2 1/2- 10"**

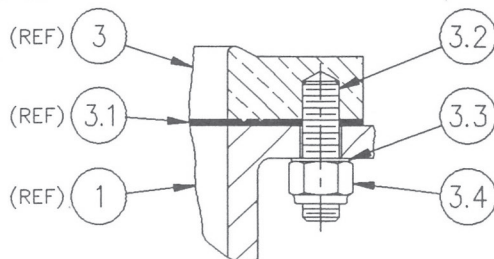
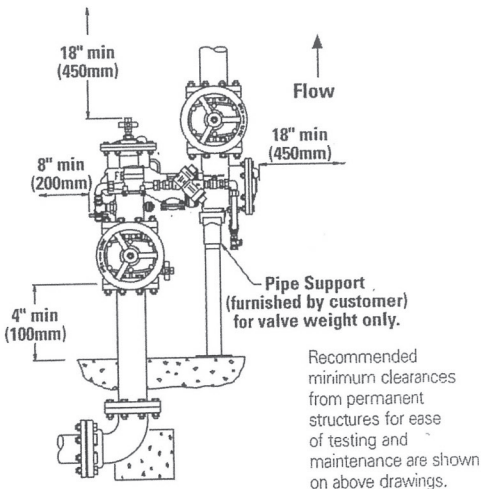

860, 866, 880, 886 and 880V (2 1/2" - 10")

CHECK VALVE

SPRING MODULE REMOVAL

1. Slowly close outlet shut-off valve and inlet shut-off valve. Bleed residual pressure by opening #4, #3, and #2 test cocks.

2. Remove cover bolts, removing the two bolts last that are located next to the retainer pin. Remove cover.

NOTE: Spring module is positioned in the body by the cover. Spring module is captured.

3. Remove pivot bearing (13) from the upper spring retainer of the spring module. Inspect pivot bearing (13) and bearing socket (15). Small hole in bearing socket indicates replacement is required. Remove retaining clip (5.1) from groove on one end of the load pin (7). Hold spring module with one hand while sliding out load pin (7) from arm (4). Lift out spring module and inspect for wear or damage. Replace spring module if necessary.

CHECK DISK REMOVAL

1. Remove jam nut (16) and washer (17) from check disc stem threads. Lift the arm and remove the check disc (6). Inspect sealing surface for debris or damage. Replace check disc if necessary.

NOTE: When jam nut (16) is tight, check disc is designed to "wobble."

SEAT RING ASSEMBLY REMOVAL

NOTE: Remove the seat ring assembly only if the seat ring (3) or arm (4) appear to be worn or damaged.

1. Remove locknuts (3.4) and washers (3.3). (See Figure No. 8 below.)

2. Remove seat ring assembly.

NOTE: When reassembling, tighten locknuts to 12 - 15 ft/lbs. If leaking occurs around bolt, further tighten until leaking stops.

3. Remove retaining clip (5) from one end of the swing pin (4.2). Hold arm (4) while sliding out swing pin (4.2). Inspect bushings (4.1) and pin (4.2) for wear or damage. Replace if necessary. Inspect gasket (3.1) for debris and/or damage. Replace if necessary.

NOTE: Reverse the procedure above, to reassemble the components. Seat ring will only fit into body one way. Check alignment of seat ring if studs don't align with body holes. Gasket is also non-symmetric. Both seat ring and gasket have a notch that indicates non-symmetric hold. Clean all parts thoroughly with clean water before reassembly. Reassemble and bleed test cocks #4, and #3. Re-pressurize the assembly and test to ensure proper operation.

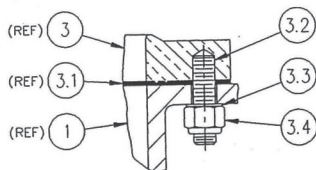
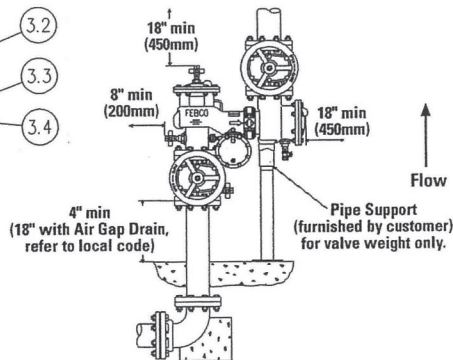

Figure No. 8



Recommended minimum clearances from permanent structures for ease of testing and maintenance are shown on above drawings.

RELIEF VALVE

RELIEF VALVE REMOVAL (See Figure No.'s 9 - 14.)

1. Remove capscrews (24), washers (24.1) and nuts (25) at base of relief valve body and hydraulic sensing port. Remove relief valve seat ring (34) from bottom of relief valve. Inspect seat ring (34), seat disc (32), and guide (33) for debris, wear, or damage. Replace as necessary.

RELIEF VALVE SEAT DISC REPLACEMENT

1. Separate relief valve from elbow and sensing line flange. Remove cover bolts (22) and cover (20).
2. Lift out diaphragm (37) and inspect for damage. Replace if necessary.
3. Grasp spring button (28) and pull out relief valve module.
4. Turn over relief valve assembly module so that guide (33) stem is facing up. Use tabs on guide (33) to loosen guide. Unscrew guide and replace seat disc (32).

REASSEMBLE IN REVERSE ORDER.

RELIEF VALVE DISASSEMBLY

1. Remove o-ring (34.1) and rv seat ring (34) from the bottom of rv body.
2. Remove rv cover (20) from rv body by removing eight capscrews (22).
3. Remove diaphragm from rv body. Remove rv assembly module from rv body (21).
4. Loosen tabs on guide (33) and remove guide and seat disc (32), remove instruction label (28.2) from center of button, covering flow screw (28.1).
5. Loosen flow screw (28.1) CAUTION spring is captured. Remove spring (29) from main guide (31), remove flow washer (30) from top of diaphragm (37).
6. Remove stem (30) and stem washer (30.1), on end of stem, from diaphragm guide assembly.
7. Unscrew retainer from main guide (31) and remove slip ring (38.1) from retainer.
8. Remove small diaphragm (37) from main guide (31).

RELIEF VALVE ASSEMBLY

NOTE: Clean all parts thoroughly with clean water before reassembly.

1. Place small diaphragm (37) into main guide (31) with beaded side of flange pointed down.
2. Drop slip ring (38.1) into retainer (38) and screw retainer into main guide (31) as shown, being careful not to bind the diaphragm's cup shape with your finger.
3. Place stem washer (30.1) on end of stem (30) and insert stem into diaphragm guide assembly. When the stem is fully inserted it does not bottom out against diaphragm, so do the following: Press diaphragm against stem with your thumb and forefinger and slowly pull the stem back out with the diaphragm. Place stem guide assembly on bench with diaphragm pointed up.
4. Place flow washer (39) on top of diaphragm (37) with slots facing up and with holes lining up. Set spring (29) on main guide (31) and compress spring with button (28). With spring fully compressed insert and tighten down flow screw (28.1), being careful not to twist button or assembly which will distort the diaphragm.
5. Stick instruction label (28.2) in center of button, covering flow screw (28.1). Install seat disc (32) into stem (30) and install guide (33) to retain disc. Using tabs on guide, tighten until shoulder on guide contacts stem.
6. Lubricate o-ring (31.1) with Dow Corning 111 Valve Lubricant & Sealant, or a design engineering approved equivalent, and install on main guide (31).
7. Install assembly into rv body (21). Place large diaphragm (27), with cap facing down, into rv body and fold over stem assembly button. Pull diaphragm flange up onto rv body flange.
8. Assemble rv cover (20) to rv body using eight capscrews (22) and tighten to 120 inch-pound torque wrench limit.
9. Insert rv seat ring (34) into bottom of rv body (aligning it with guide 33) and install o-ring (34.1).

N-SHAPE ONLY - Assemble complete relief valve assembly to valve body as shown with o-ring (35) and back-up ring (35.1), using four capscrews (24), eight washers (24.1) and four nuts (25). Tighten to 120 inch-pounds torque wrench limit. Attach sensing line flange cover (36).

IN-LINE ONLY - Assemble completed unit to valve body and elbow with gasket (26) install with screen facing valve body) using six capscrews (24), twelve washers (24.1) and six nuts (25). Tighten to 120 inch-pounds torque wrench limit.

Check Valve Service Procedures (2 1/2"-10") for (2 1/2"-10") LF850, LF 870V, LF856, LF876V

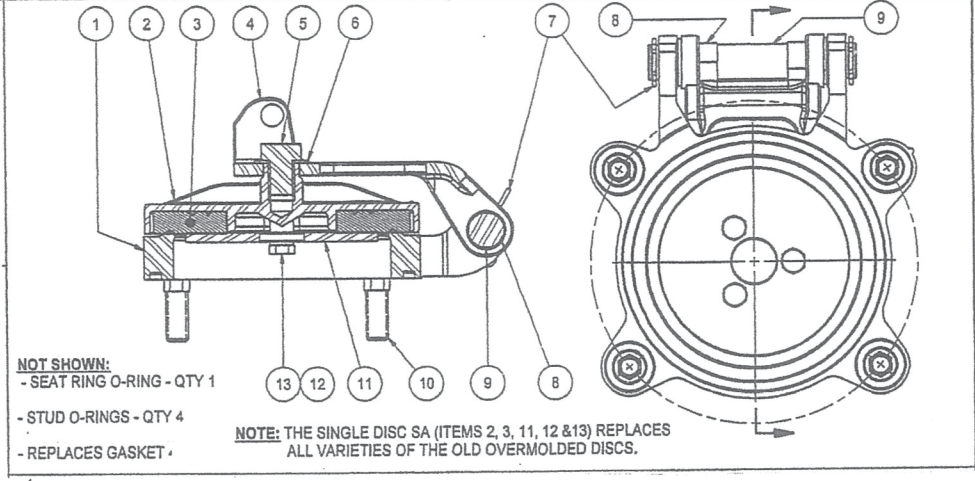
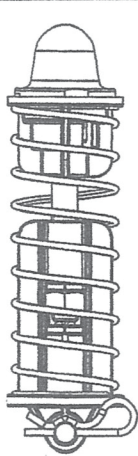

NOT SHOWN:
 - SEAT RING O-RING - QTY 1
 - STUD O-RINGS - QTY 4
 - REPLACES GASKET

NOTE: THE SINGLE DISC SA (ITEMS 2, 3, 11, 12 & 13) REPLACES ALL VARIETIES OF THE OLD OVERMOLDED DISCS.

Check Mechanism

ITEM	DESCRIPTION
1	SEAT RING 2-1/2" & 3"
2	DISC HOLDER 2-1/2" & 3"
3	DISC 2-1/2" & 3"
4	ARM 2-1/2" & 3"
5	HHCS 3/8-16UNC-2Bx.50
6	WASHER, .375 ID X .75 OD X .041
7	HAIRPIN CLIP
8	BUSHING-SWING PIN
9	SWING PIN
10	HEX STUD 5/16-18 x 1-1/4
11	DISC RETAINER 2-1/2" & 3"
12	#10 SPLIT LOCK WASHER
13	HH MACH SCREW #10-24UNCx3/8

Check Valve Disassembly

1. Close the outlet shutoff valve, then close the inlet shutoff valve. Bleed residual pressure from the assembly by opening the #4, #3, and #2 test cocks in this sequence.
2. Remove the cover bolts/nuts and lift the cover from the body. The springs are retained and the cover should be pushed away from the body approximately 1/4 inch.

3. Inspect/clean debris from the disc and seat ring. Replace worn or damaged parts as required.
4. Replace the cover, ensure the spring assembly is positioned in the pivot socket. If necessary, apply FDA approved grease to the O-ring groove in the body to keep the O-ring in position while installing the cover.
5. Install the bolts and nuts and tighten.

Relief Valve Service Procedures (2 1/2"-10") for LF860, LF 880V, LF866, LF886V

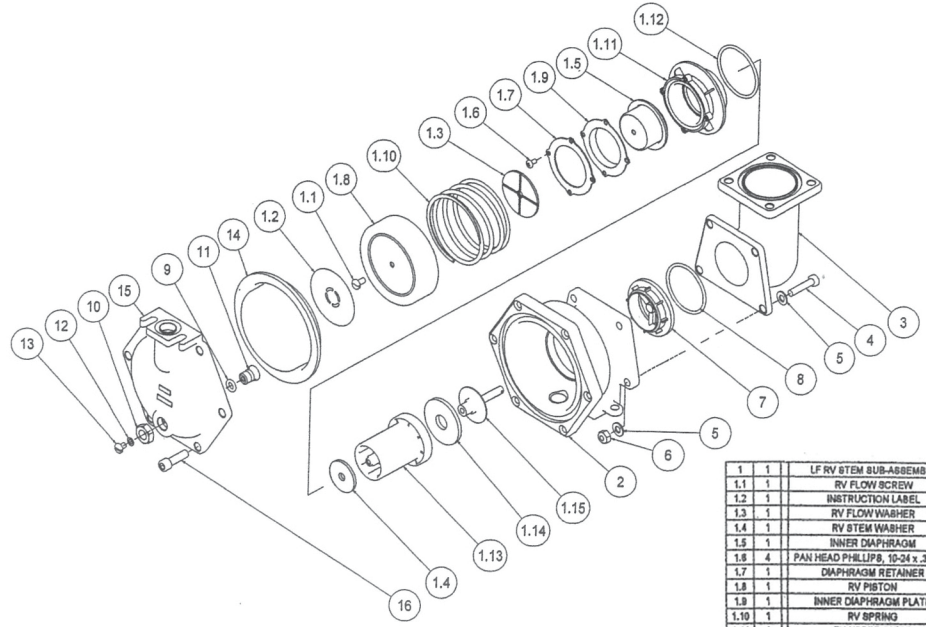

1	1	LF RV STEM SUB-ASSEMBLY
1.1	1	RV FLOW SCREW
1.2	1	INSTRUCTION LABEL
1.3	1	RV FLOW WASHER
1.4	1	RV STEM WASHER
1.5	1	INNER DIAPHRAGM
1.6	4	PAN HEAD PHILLIP# 10-24 x .375 LG
1.7	1	DIAPHRAGM RETAINER
1.8	1	RV PISTON
1.9	1	INNER DIAPHRAGM PLATE
1.10	1	RV SPRING
1.11	1	RV UPPER GUIDE
1.12	1	O-RING -238
1.13	1	RV MAINSTEM
1.14	1	RV SEAT DISC
1.15	1	RV LOWER GUIDE
2	1	RV BODY
3	1	RV ELBOW 880
4	4	5/16-18 X 1-1/2 HHB
5	8	5/16 FLAT WASHER TYPE A
6	4	5/16-18 UNC ELASTIC STOP NUT
7	1	RV SEAT RING
8	1	O-RING -228
9	2	O-RING -204
10	2	HEX NUT
11	2	RV DRAIN PLUG BLEEVE
12	2	GASKET
13	2	PAN HD SCREW
14	1	OUTER DIAPHRAGM
15	1	RV COVER
16	8	BHCS 3/8-16 X 1.25
ITEM	QTY	DESCRIPTION

Relief Valve Disassembly

1. Remove the capscrews holding the cover to the relief valve body, and remove the cover.
2. Remove the diaphragm and pull the internal assembly from the body. It may be helpful to push the internal assembly with your fingers through the discharge opening.
3. Inspect for debris, damage or fouling of the seat disc. Clean or replace parts as required. Reassemble in the reverse order of disassembly.

INSTALLATION INSTRUCTIONS

LF860, LF866, LF880V, LF886V

Relief Valve
 Size: 2 1/2" - 10"

WARNING

Read this Manual BEFORE using this equipment. Failure to read and follow all safety and use information can result in death, serious personal injury, property damage, or damage to the equipment. Keep this Manual for future reference.

Proper installation of FEBCO Relief Valve Inner Diaphragm into the Relief Valve Upper Guide for Models LF860, LF866, LF880V, LF886V

NOTICE
 Failure to install inner diaphragm in this method will result in the inner diaphragm bursting after installation.

