

# Series 770 – 772

## Spring Guide Assembly Removal Instructions

1. The 772 features a captured spring in a center stem guided assembly. The spring guide assembly must be removed to clean the seat disc. As with any spring loaded mechanism, keep fingers away from pinch points. The spring guide assembly has a heavy spring pre-load and could cause injury. It is not necessary to disassemble the spring guide assembly.
2. Remove the access cover.
3. Apply leverage between the spring guide assembly and the disc assembly as shown in Fig. 1.
4. Compress the spring guide assembly slightly so it will pop free from the notches on the disc assembly and rest as shown in Fig. 2.
5. Completely remove the spring guide assembly by unhooking the two outlet end ears from the mounting bracket.

## Disc Assembly Removal Instructions

1. Remove the access cover.
2. Remove the spring guide assembly.
3. Unfasten the two bolts on the bottom of the body opposite the access cover.
4. Reach in through the access opening and remove the entire clapper assembly. Opening the clapper assembly, and laying it flat on a table (refer to Fig. 3).
5. With an allen wrench, remove the set-screw which secures the spacer to the retainer pin on the clapper assembly.
6. Slide out the retainer pin to separate the disc assy from the mounting bracket.

## CHECK VALVES 4", 6", 8" and 10"

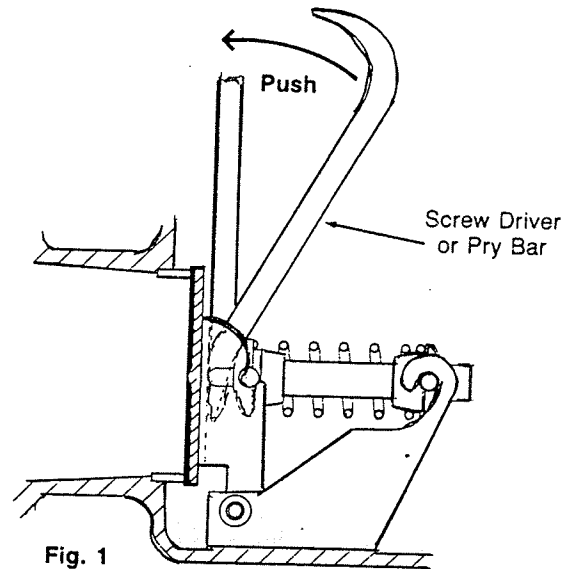
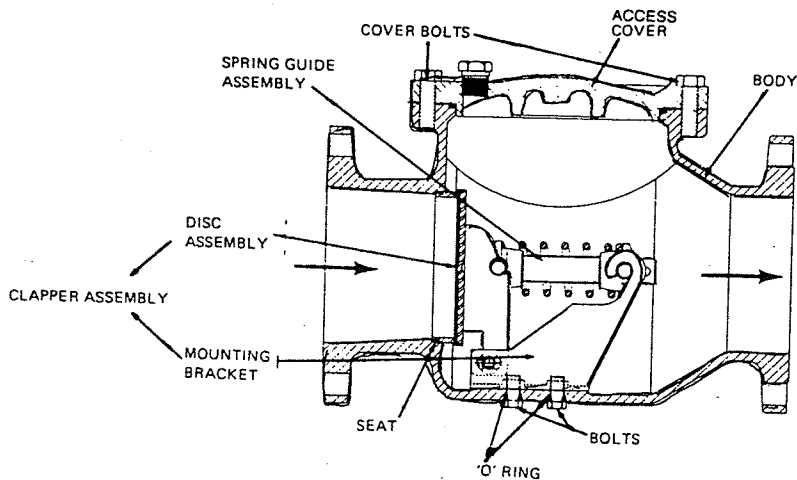

Fig. 1

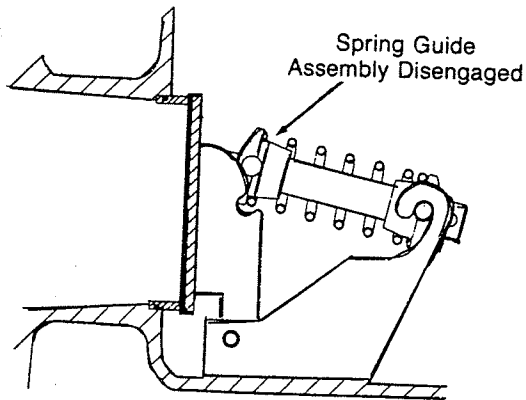

Fig. 2

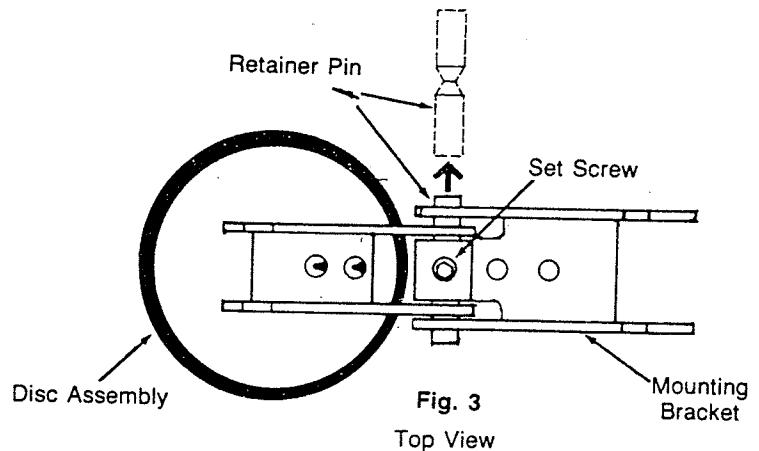

Fig. 3  
Top View