

# Series 909

Sizes 2½" - 10"

1. Remove the hatch cover bolts. NOTE: The 909 is designed so that when the bolts are backed off ½", all the spring load is released from the cover and retained by the check module. **CAUTION: Be sure to verify this before removing all the bolts.**
2. Lift the check valve module straight out taking care not to hit and damage the seat ring.
3. The seat ring may be removed and replaced by pulling out the two wire retainers on sizes 4" - 10" while on sizes 2½" - 3", one quarter-turn twist removes seat. The wire retainers are 10" long. One is drawn out clockwise and the other is drawn out counter clockwise.
4. With the retainer wires removed, the seat ring can be lifted straight up and removed.

5. **CAUTION:** The check valve spring is in compression. The spring load is captured by the two spring retainers and the stem. The spring retainers are not to be removed for servicing. If there is a need to replace the spring, spring retainer or stem, an assembled module must be obtained from the factory. These modules are **not** interchangeable, be sure to replace the first check with a first check module and the second check with a second check module.
6. To replace the disc on sizes 2½" - 4" simply remove the retaining nut or for sizes 6" - 10" remove the allen head socket screws. Reverse this procedure to install the new disc.

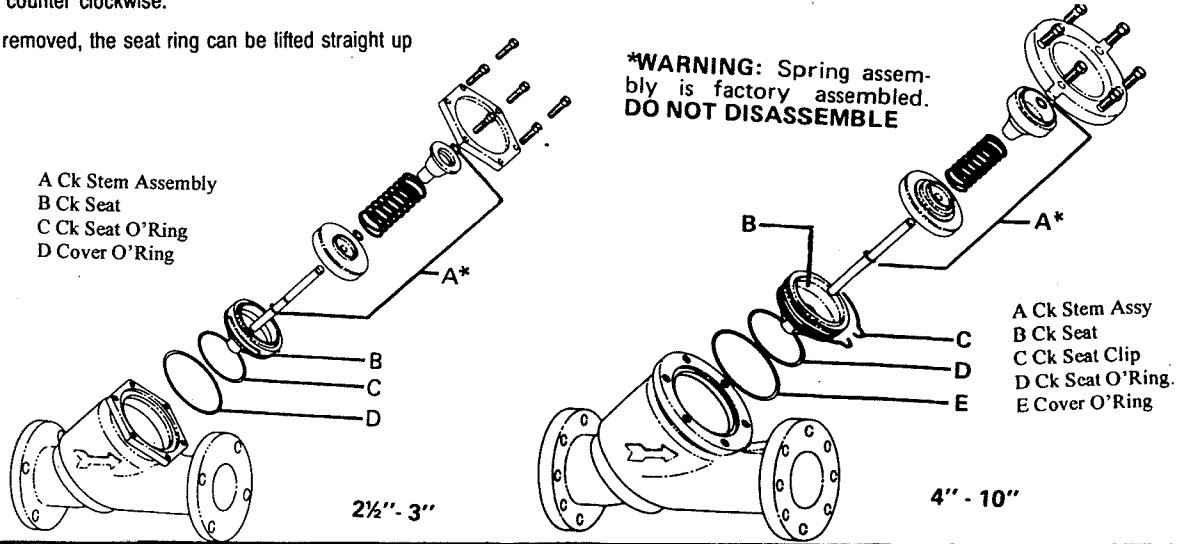

1. Remove the relief valve cover bolts. Note the 909 is designed so that when the bolts are backed off ½" all the relief valve spring load is retained by the bottom plug spring module. **CAUTION: Be sure to verify this before removing all the bolts.**
2. Remove the cover and diaphragm (A). The relief valve piston assembly (B) can be lifted straight up and out.
3. Replace the wiper seal and piston "O" ring and apply grease to the "O" ring.

4. To replace the relief valve disc, hold the upper guide fin and unscrew the diaphragm pressure plate. It may be necessary to lightly tap the cast webs and the pressure plate to loosen. Replace with a new disc holder assembly and "O" ring. Note: the disc rubber is molded into the disc holder and is supplied as a disc holder assembly.
5. Removal of the bottom spring assembly (E). During normal field service there is no need to remove the bottom plug spring assembly other than inspection. It can be removed by simply unscrewing with a large pipe wrench. **CAUTION:** The spring as retained on the bottom plug is highly loaded. NO attempt should be made in the field to remove the spring. For replacement, a complete bottom plug assembly must be obtained from the factory.

