

Maintenance Instructions

CHECK ASSEMBLY

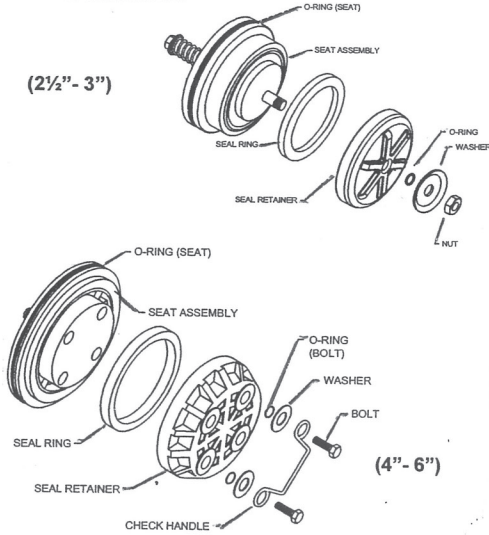

All Model 350/450 Double Check Valve Backflow Preventers must be inspected and maintained by licensed personnel at least once a year or more frequently as specified by local codes. Replacement of worn or damaged parts must only be made with genuine "WILKINS" parts.

GENERAL MAINTENANCE

1. Clean all parts thoroughly with water after disassembly.
2. Carefully inspect rubber seal rings and o-rings for damage.
3. Test unit after reassembly for proper operation (refer to "TESTING PROCEDURES").

NOTE: If any portion of the seat assembly is damaged or missing or if the seating surface is damaged in any way, do not attempt to field repair it. Contact your local WILKINS representative for assistance.

SERVICING CHECK VALVES

1. Close the outlet and then the inlet shut-off valves.
2. Open No. 2, 3 and 4 test cocks to release internal pressure. Leave them open during check removal and reinstallation.
3. Loosen and remove the two nuts, bolts and gasket from the grooved coupling around the access cover.
4. If the valve has a wire retainer on the #1 check assembly, pinch together the exposed ends, pull toward the #2 check and remove from valve.
5. If the valve has a plastic retainer on the #1 check, grasp one of the exposed ends, push down and then pull toward the #2 check. The retainer should "spiral" out of the groove around the check.
6. (2-1/2 - 3" Models) Remove the #2 retainer and check in the same manner as the #1.
7. (4 - 6" Models) Remove the #2 check by locating one of the two spring-loaded plate retainers around the face of the check. Pinch the sides of the spring together and rotate the plates out of the body groove one at a time. Remove the 2nd retainer the same way.
8. **Always service the checks one at a time to avoid mixing parts.** Start by removing the hardware and o-rings from the back of the check assembly (See "Check Assembly" illustration). Separate the seal retainer from the assembly to expose the seal ring.
9. Inspect the seal ring for cuts or embedded debris. If the reverse side of the seal is unused, the seal ring can be inverted and used temporarily until a new seal is obtained. (2 1/2" & 3" Models) Tighten check assembly nut between 20-25 ft/lbs of torque. Inspect seat o-ring and replace if cut or damaged in any way.
10. Inspect valve cavity and seating areas. Flush with water to remove any debris.
11. (Reassembly, 2-1/2 - 3" Models) Lubricate the #2 check o-ring, install in the body and close the #4 test cock to hold it in place. Install the plastic retainer by inserting one end into the body groove and then sliding your hand around the face of the retainer, pushing it into the groove as you go. The retainer will "snap" into place when fully seated. Install #1 check and retainer in the same way.
12. (Reassembly, 4 - 6" Models) Lubricate the #2 check o-ring, install in the body and close the #4 test cock. Install the #2 check retainers into the body groove one plate at a time, squeezing the spring ends together to clear the stops on the face of the seat. Lubricate and install the #1 check, close the #2 test cock and install:
 - (A) wire retainer by pinching the ends together, placing the lower edge of the ring into the body groove below the check and rotating the top of the ring into the notch above the check.
 - (B) plastic retainer as described above in the 2-1/2 - 3" Models Reassembly section.
13. Lubricate the outside surface of the grooved coupling gasket. Reassemble access cover and grooved coupling, making sure the ends of the coupling touch each other. Close any remaining open test cocks and place valve back in service.

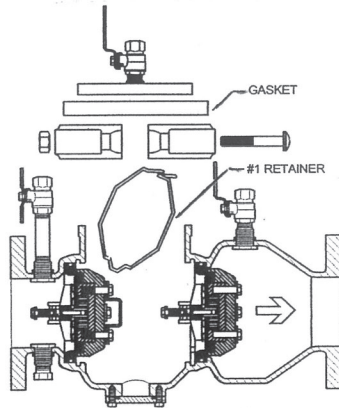

FIGURE 1

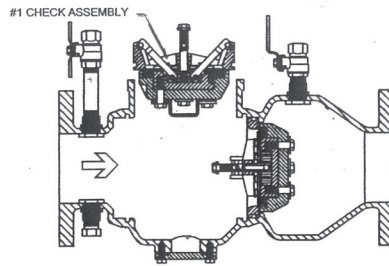

FIGURE 2

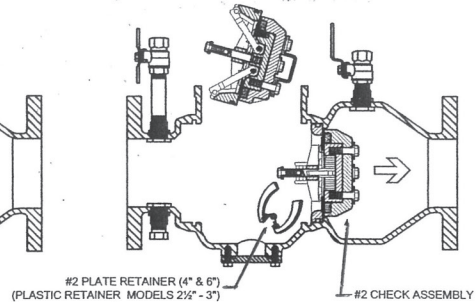

FIGURE 3

350 / 350DA

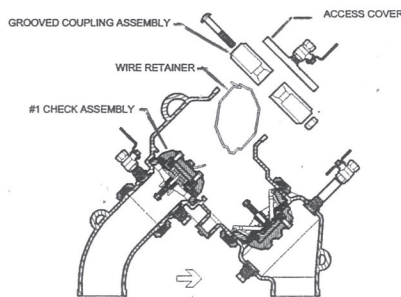

FIGURE 1

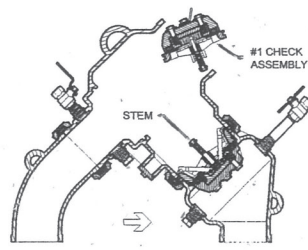

FIGURE 2

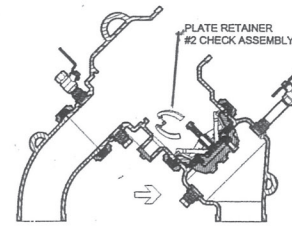
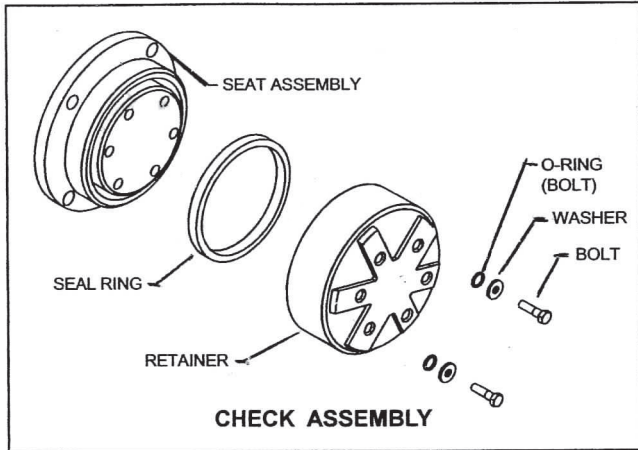

FIGURE 3

450 / 450DA

Maintenance Instructions



All Model 350 Double Check Valve Backflow Preventers must be inspected and maintained by licensed personnel at least once a year or more frequently as specified by local codes. Replacement of worn or damaged parts must only be made with genuine "WILKINS" parts.

GENERAL MAINTENANCE

1. Clean all parts thoroughly with water after disassembly.
2. Carefully inspect rubber seal rings and o-rings for damage.
3. Test unit after reassembly for proper operation (refer to "TESTING PROCEDURES").

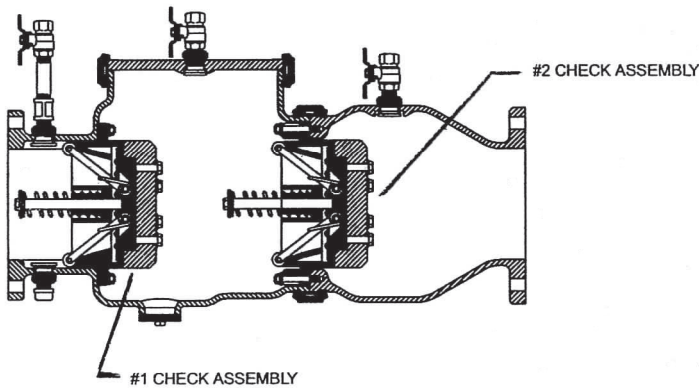

350 / 350DA

SERVICING CHECK VALVES

1. Close inlet and outlet shut-off valves.
2. Open No. 2, No. 3 and No. 4 test cocks to release pressure from valve.
3. Loosen & remove the grooved coupling around the access cover. Remove cover.
4. To service only the #1 check assembly, remove the 6 bolts, washers and o-rings from the back of the #1 check assembly. Separate the retainer and the seal ring from the check assembly and proceed to step #8.
5. To service both checks or the #2 check, the #1 check assembly must first be removed. Remove the 4 nuts and washers retaining the #1 check assembly. Remove the #1 check assembly from the body.
6. To remove the #2 check assembly, remove the 7 nuts, washers and the #2 check retaining ring. Grasp the check assembly by the stem and remove from valve.
7. Remove all 6 bolts, washers and o-rings from the check assembly (See "Check Assembly" illustration). Separate retainer from check assembly to expose seal ring for inspection.
8. Inspect the rubber seal ring for cuts or embedded debris. If the reverse side of the seal ring is unused, it is possible to invert the seal ring. This would be considered a temporary solution to fixing a fouled check and should be replaced with a new seal ring as soon as possible.
9. Inspect valve cavity and seating areas. Remove any debris.
10. Reverse the above procedures to reinstall check assemblies. Lubricate seat o-rings to hold them in place while reinstalling seat. Place washers on studs and tighten retaining nuts evenly.
11. Reinstall access cover and grooved coupling.

NOTE: If any portion of the seat assembly is damaged or missing or if the seat sealing rib is damaged in any way, do not attempt to field repair it. Contact your local WILKINS representative for assistance.

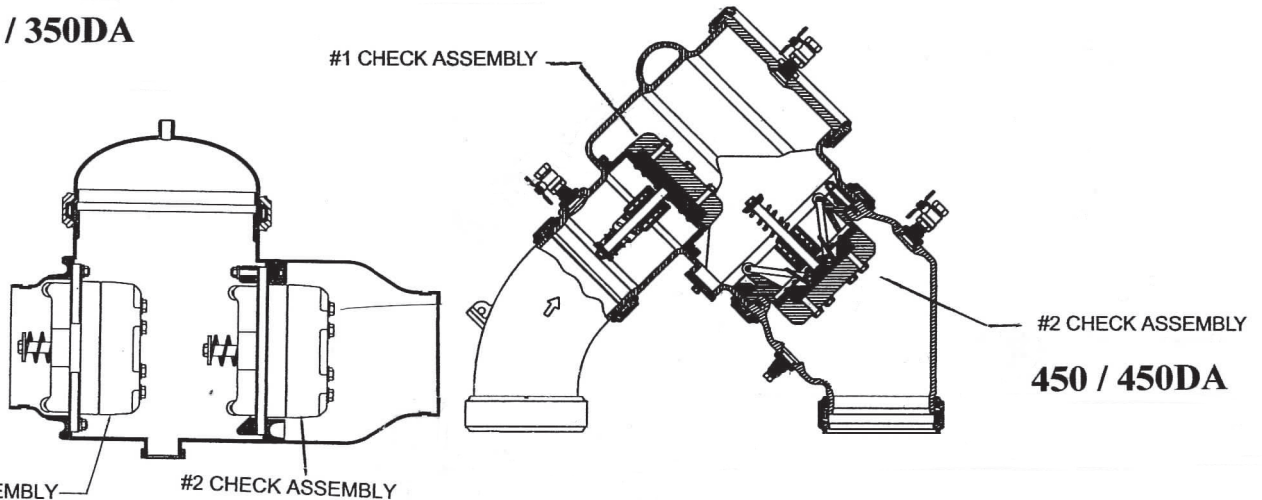

350 AST

#1 CHECK ASSEMBLY #2 CHECK ASSEMBLY

450 / 450DA