

AMES 4000CIV

SIZE

2 1/2", 3", 4", 6", 8", 10"

DESCRIPTION

This is a reduced pressure principle assembly. Production began in 1998 and was discontinued in 2007. The Ames Company was purchased by Watts Regulator Company in 1997. Ames began marketing the Watts 909 as the Ames 4000CIV. For breakdown information see Watts 909. The body is constructed of fused epoxy cast iron. The check springs are contained when the covers are removed. The check seats are replaceable. The relief valve utilizes an external relief valve sensing line. The relief valve spring is contained when the relief valve cover is removed. The relief valve seat is replaceable.

BASIC REPAIR KIT

Repair kit contains discs, diaphragm, and O-rings

<u>SIZE</u>	<u>KIT NO</u>
2 1/2"-3"	LF909-RT250
4"	LF909-RT400
6"	LF909-RT600
8"	LF909M1-RT800
10"	LF909M1-RT001

IMPORTANT FEATURES

~See Watts 909

MODEL 4000CIV

Reduced Pressure Zone Backflow Preventer

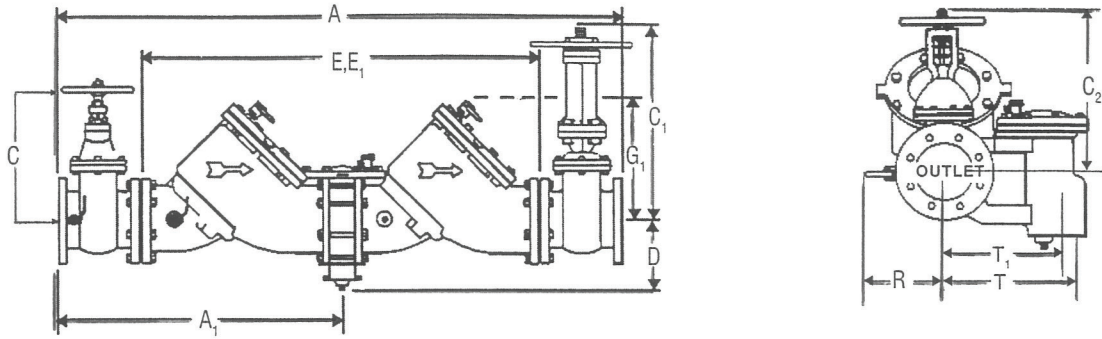

Size (DN)		A		A ₁		NRS		OS&Y*		Service Clearance for Gate OS&Y Open C ₁		Service Clearance for Gate NRS C ₂		D		E, E ₁		Service Clearance For Check G ₁	
in.	mm	in.	mm	in.	mm	in.	mm	in.	mm	in.	mm	in.	mm	in.	mm	in.	mm	in.	mm
2 1/2	65	4 1/4	1048	2 0 5/8	524	1 1 3/8	289	1 5 7/8	403	1 6 3/8	416	1 4	356	5 1/4	133	2 6 1/8	663	1 1	279
3	80	4 2 1/4	1073	2 1 1/4	540	1 2 3/4	324	1 8 1/2	470	1 8 7/8	479	1 4	356	5 1/4	133	2 6 1/8	663	1 1	279
4	100	5 5 1/8	1400	2 7 5/8	702	1 5 3/8	603	2 3 3/4	603	2 2 3/4	578	1 7	432	6	152	3 7	940	1 4	356
6	150	6 5 1/2	1664	3 2 3/4	832	1 9 3/4	825	3 2 1/2	825	3 0 1/8	765	2 1	533	6	152	4 4 1/2	1130	1 6	406
8	200	7 8 1/2	2000	3 9 3/8	1000	2 4 1/2	622	3 9 1/4	997	3 7 3/4	959	2 6	660	9 3/4	248	5 5 1/4	1403	2 1	533
10	250	9 3 3/8	2378	4 6 7/8	1190	2 9 1/4	743	4 8	1220	4 5 3/4	1162	3 2	813	9 3/4	248	6 7 3/8	1711	2 1	533

Size		R		T		T ₁		NRS		OS&Y	
in.	mm	in.	mm	in.	mm	in.	mm	lbs.	kgs.	lbs.	kgs.
2 1/2	64	4	102	9 1/16	230	7 5/8	194	195	88.4	198	89.8
3	76	5	127	9 1/16	230	7 5/8	194	225	102	230	104
4	102	6	152	1 4 3/8	365	1 2 1/2	318	455	206	470	213
6	152	11	279	1 4 3/8	365	1 2 1/2	318	718	326	798	362
8	203	1 1 1/4	286	1 9 1/4	489	1 7 3/8	441	1350	612	1456	660
10	254	1 2 1/2	318	2 1	533	1 9 1/8	486	2160	980	2230	1011

*UL, FM approved backflow preventers must include UL/FM approved OS&Y gate valves.

PHYSICAL CHARACTERISTICS

Sizes: 2 1/2", 3", 4", 6", 8", 10"
(65, 80, 100, 150, 200, 250mm)

Suitable for supply pressure up to 175 psi (12 bars) and water temperatures to 110°F (43°C) continuous and 140°F (60°C) intermittent.

IMPORTANT: INQUIRE WITH GOVERNING AUTHORITIES FOR LOCAL INSTALLATION REQUIREMENTS.

Note: The installation of a drain line is recommended. When installing a drain line, an air gap is necessary. Contact Factory to obtain air gap drain information.

CAPACITY

* Typical maximum system flow rate (7.5 feet/sec.)

