

AMES C500

SIZE

2 1/2", 3", 4", 6", 8", 10"

DESCRIPTION

This is a reduced pressure detector assembly. This model was produced under the Hunter name from 2000-2002. In 2002 Watts bought the Hunter models and began production as the Ames C500. Watts will produce this model under the Watts name as the model 957RPDA. The mainline assembly is similar in construction to the M400. The bypass assembly is the Flomatic RPZE 3/4" or Watts 919 3/4".

BASIC REPAIR KIT

Repair kit contains disc and O-rings for both check modules, RV piston, and rolling diaphragm.

<u>SIZE</u>	<u>KIT NO</u>	<u>AIR GAP DRAIN</u>
C500 2 1/2"-4"	400CRT250	7019628
C500 6"	400CRT600	7019628
C500 8"	400CRT800	7019628
C500 10"	400CRT001	7019628

Bypass repair kit contains all check discs, O-rings, and diaphragm

<u>SIZE</u>	<u>KIT NO</u>
Flomatic RPZ 3/4"	B92RK00 ◆
Watts 919 3/4"	919-RT075

IMPORTANT FEATURES

- ~2 1/2"-6" check access slides open
- ~Body is stainless steel
- ~Factory repair information enclosed



Colt™ Series C500, C500N, C500Z

Reduced Pressure Detector Assemblies

Sizes: 2½" – 10" (65 – 250mm)

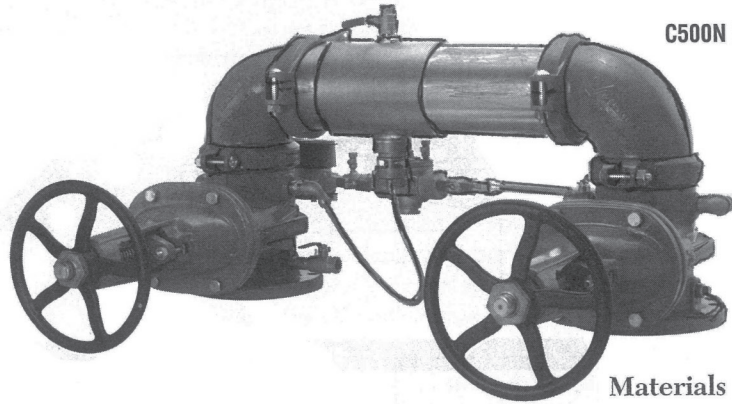

C500N OSY

Features

- Extremely Compact Design
- 70% Lighter than Traditional Designs
- 304 (Schedule 40) Stainless Steel Housing & Sleeve
- Groove Fittings Allow Integral Pipeline Adjustment
- Patented Link Check Provides Lowest Pressure Loss
- Unmatched Ease of Serviceability
- Replaceable Check Disc Rubber
- Available with Grooved Butterfly Valve Shutoffs
- Bottom Mounted Cast Stainless Steel Relief Valve
- Metered Bypass to Detect Leakage or Theft of Water from the Fire Sprinkler System

Available Models

Suffix:

OSY – UL/FM, outside stem and yoke, resilient seated gate valves

BFG – UL/FM grooved gear operated butterfly valves with tamper switch

Pressure — Temperature

Temperature Range: 33°F – 140°F (5°C – 60°C)

Maximum Working Pressure: 175psi (12.06 bars)

Materials

- Housing & Sleeve: 304 (Schedule 40) Stainless Steel
- Elastomers: EPDM, Silicone and Buna 'N'
- Link Checks: Noryl®, Stainless Steel
- Check Discs: Reversible Silicone or EPDM
- Test Cocks: Bronze Body Nickel Plated
- Pins & Fasteners: 300 Series Stainless Steel
- Springs: Stainless Steel

Approvals



For additional approval information please contact the factory or visit our website at www.amesfirewater.com

Colt™ Series C500, C500N, C500Z

H – Horizontal

V – Vertical

N-N Pattern

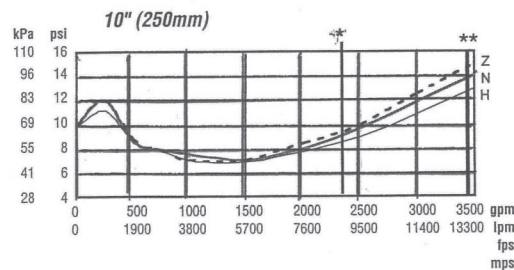
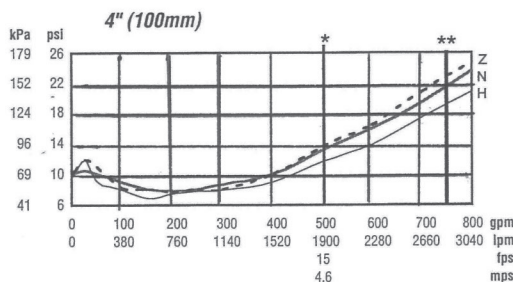
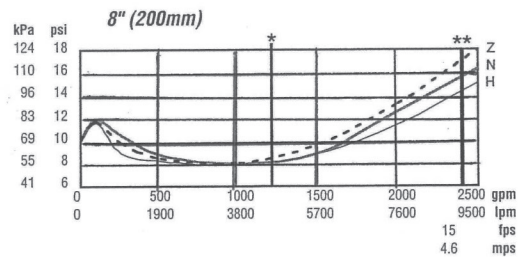
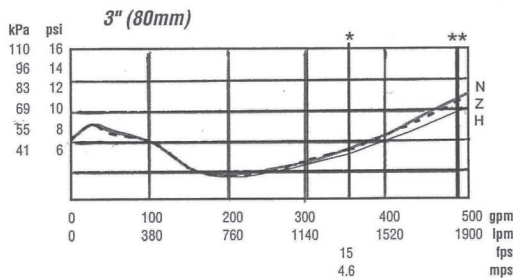
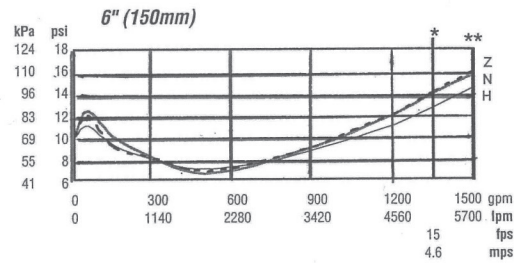
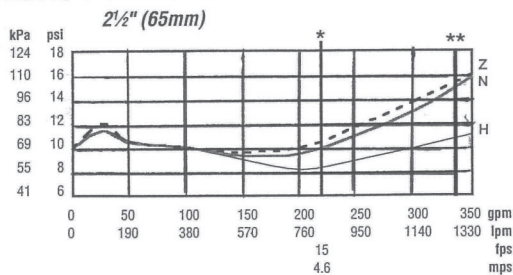

Dimensions — Weights

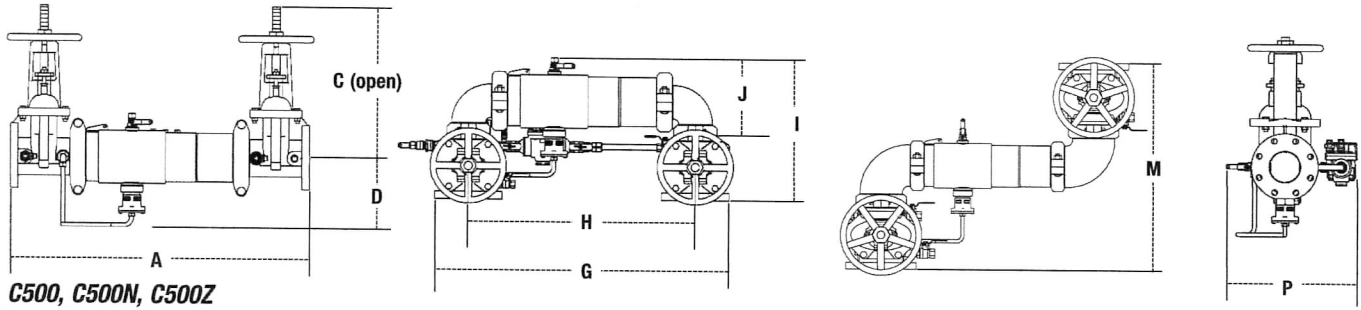

C500, C500N, C500Z

SIZE (DN)		DIMENSIONS										WEIGHT											
in.	mm	A		C (OSY)		D		G		H		I		J		M		P		C500		C500N	
		in.	mm	in.	mm	in.	mm	in.	mm	in.	mm	in.	mm	in.	mm	in.	mm	in.	mm	lbs.	kgs.	lbs.	kgs.
2½	65	30¾	781	16¾	416	6½	165	29⅞	738	21½	546	15½	393	8⅞	223	21¼	540	13⅞	335	142	64	150	68
3	80	31¼	806	18⅞	479	6⅞	170	30¼	768	22¼	565	17⅞	435	9⅞	233	23	584	14½	368	162	73	175	79
4	100	33¾	857	22¾	578	7	178	33	838	23½	597	18½	470	9⅞	252	26¼	667	15⅞	386	178	81	201	91
6	150	43½	1105	30⅞	765	8½	216	44¾	1137	33¼	845	23⅞	589	13⅞	332	32¼	819	19	483	312	142	353	160
8	200	49¾	1264	37¾	959	9⅞	246	54⅞	1375	40⅞	1019	27⅞	697	15⅞	399	36⅞	937	21⅞	538	497	225	572	259
10	250	57¾	1467	45¾	1162	11⅞	285	66	1676	49½	1257	32½	826	17⅞	440	44½	1124	24	610	797	362	964	437

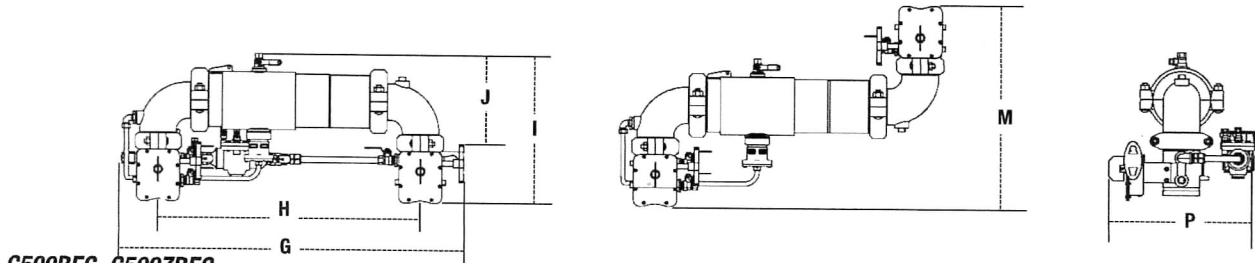

C500BFG, C500ZBFG

SIZE (DN)		DIMENSIONS						WEIGHT							
in.	mm	G		H		I		J		M		P		C500BFG	
		in.	mm	in.	mm	in.	mm	in.	mm	in.	mm	in.	mm	lbs.	kgs.
2½	65	32½	826	23	584	15½	394	9½	241	19¾	502	15⅞	402	81	37
3	80	34	864	24	610	16⅞	414	10⅞	256	21¼	540	16⅞	410	84	38
4	100	35⅞	905	25½	648	17⅞	437	10⅞	279	23½	597	16⅞	422	101	46
6	150	46½	1181	35¼	895	20½	521	13½	343	27¼	692	19	483	174	79

Noryl® is a registered trademark of SABIC Innovative Plastics™.

Check Valve

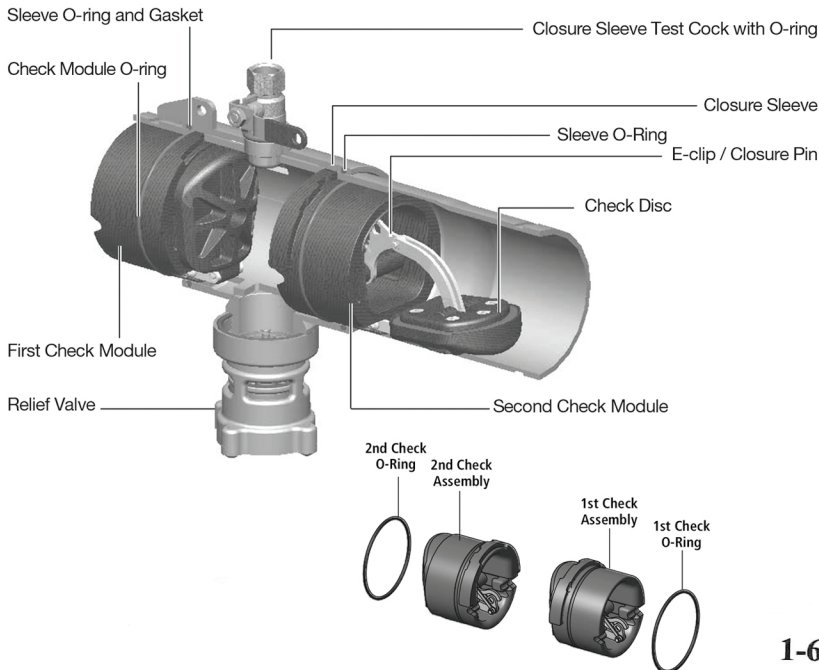

Relief Valve

