

# WATTS

## 009/ 009M1/ 009 M2/ 009 M3

### LF009

#### SIZE

1/4", 3/8", 1/2", 3/4", 1", 1 1/4", 1 1/2", 2", 2 1/2", 3"

#### DESCRIPTION

This is a reduced pressure assembly. Production began in 1989. All versions in the 1/2"-2" sizes utilize a bronze body design. In 2010 the LF model was introduced which utilizes a lead free bronze body design. The check modules and relief stem assembly can be removed from the top through a single cover. The checks are a modular in-line design and are held in the body by a retainer. All seats are replaceable. Check springs are contained when the modules are removed from the body. Spring tension had to be released to perform a proper repair. There is spring tension exerted on the cover from the relief valve spring. There have been several modifications over the years but all versions utilize a similar construction. Be sure which version and size you have because repair parts are different. The 009 was the original model that was produced from 1989-1991. It was modified in 1991 to the 009 M1 model in sizes 1 1/4"-2" which was produced from 1991-1992. In the 009 M1 model there was a change in the check seat dimensions. The 009 M2 design began in 1992. The major difference in the M2 design was the down sizing of the body and the internal repair parts. Relief valve sensing line is internal on all models. Internal check hardware is mostly plastic. The 1/2" model 009 was introduced in 1992. The 3/4" 009M3 began in 1998. A model U009 was developed in sizes 1/2"-2". This unit incorporates a union end into the body. The U009A utilizes the same union with a 90 degree elbow for an up and down piping orientation. The model 009 PC is a polymer coated bronze assembly available in sizes 3/4"-2". The model SS 009 is available in 1/4"-1" sizes and is similar to the 009 except the body is made of stainless steel instead of bronze. The 2 1/2"-3" have the same features as the smaller 009 except the body is made of fused epoxy coated cast iron. The relief valve sensing line is external on 2 1/2"-3". The internal check and RV hardware are mostly bronze. In 2010 a LF model was introduced in sizes 2 1/2"-3" which replaced the leaded bronze parts with plastic and stainless steel to make it a lead free assembly.

#### BASIC REPAIR KIT

The repair kit contains all disc holders or discs, diaphragms, and O-rings

<u>SIZE</u>	<u>KIT NO</u>					<u>AIR GAP</u>
	<u>009</u>	<u>009M1</u>	<u>009M2</u>	<u>009M3</u>	<u>DRAIN</u>	
1/4"-1/2"	009RT050	N/A	N/A	N/A	N/A	AGA
3/4"	009RT075	N/A	009M2RT075	009M3RT075	N/A	AGC or A
1"	009RT075	N/A	009M2RT100	N/A	N/A	AGC
1 1/4"	009RT125	009M1RT125	009M2RT125	N/A	N/A	AGF
1 1/2"	009RT125	009M1RT125	009M2RT125	N/A	N/A	AGF
2"	009RT125	009M1RT125	009M2RT200	N/A	N/A	AGF
2 1/2"	009RT250	N/A	N/A	N/A	N/A	AGF
3"	009RT250	N/A	N/A	N/A	N/A	AGF

#### IMPORTANT FEATURES

- ~1/2"-2" bronze body
- ~2 1/2"-3" fused epoxy cast iron body
- ~Replaceable seats
- ~Spring tension when cover is removed
- ~Contained check springs
- ~Factory repair information enclosed



# Series 009QT

## REDUCED PRESSURE ZONE BACKFLOW PREVENTER

Sizes: 1/2" - 2"

The Watts Series 009QT Reduced Pressure Zone Backflow Preventers are designed to provide protection of the potable water supply in accordance with national plumbing codes and water utility authority requirements. This series can be utilized in a variety of installations, including high hazard cross connections in piping systems or for containment at the service line entrance.

This series features two in-line, independent check valves, captured springs and replaceable check seats with an intermediate relief valve. A compact modular design concept facilitates easy maintenance and assembly access. All sizes are constructed with NPT body connections and standardly furnished with ball type test cocks. Series 009QT has quarter turn, full port, resilient seated, bronze ball valve shut-offs. 1/2", 3/4" and 1" shutoffs have tee handles.

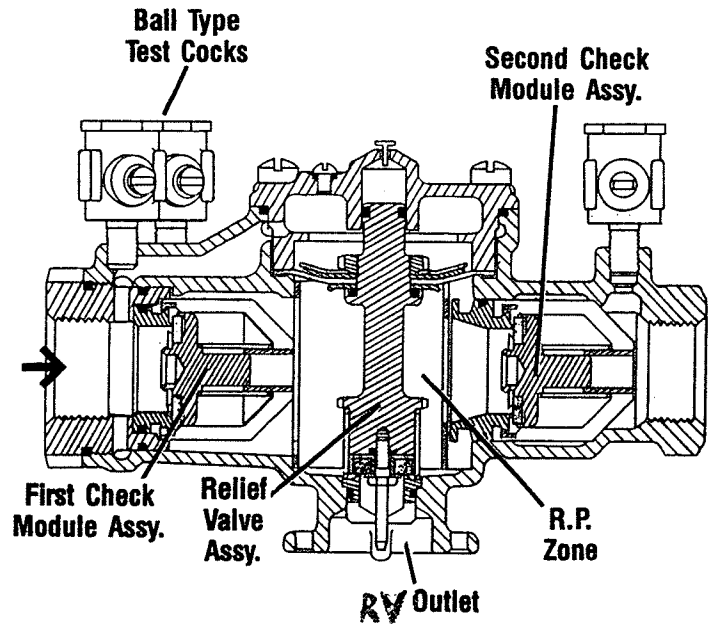

### FEATURES

- Single access cover and modular check construction for ease of maintenance
- Top entry - all internals immediately accessible
- Captured springs for safe maintenance
- Internal relief valve for right and left hand installations
- Replaceable seats for economical repair
- Bronze body construction for durability
- Ball valve test cocks - screwdriver slotted
- Large body passages provides low pressure drop
- Compact, space saving design
- No special tools required for servicing

### MATERIALS

Bronze body construction, silicone rubber for drip tight disc material in the first and second check plus the relief valve. Replaceable polymer check seats for first and second checks. Removable stainless steel relief valve seat. Stainless steel cover bolts. Standardly furnished with NPT body connections. For optional bronze union inlet and outlet connections, specify prefix U (3/4" - 2"). Series 009QT furnished with quarter turn, full port, resilient seated, bronze ball valve shutoffs.

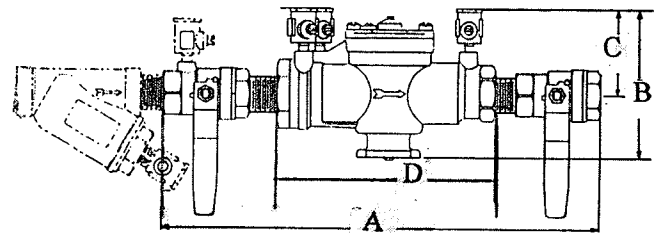

Size	Model	A	B	C	D	Weight lbs
1/2"	009	10"	4 5/8"	3 3/8"	5 1/2"	4.5
3/8"	009	10"	4 5/8"	3 3/8"	5 1/2"	4.5
1/2"	009	10"	4 5/8"	3 3/8"	5 1/2"	4.5
3/4"	009	14 3/4"	5 1/2"	3 1/8"	9 1/2"	11.0
3/4"	009M2	10 3/4"	5"	3 1/2"	6 3/4"	5.75
3/4"	009M3	10 3/4"	5"	3 1/2"	6 3/4"	5.75
1"	009	14 1/2"	5 1/2"	3 1/8"	9 1/2"	12.25
1"	009M2	14 1/2"	5 1/2"	3"	9 1/2"	12.25
1 1/4"	009	21 1/8"	7 3/4"	4 1/4"	-	28.12
1 1/4"	009M1	22 1/8"	7 3/4"	4 1/4"	-	26.5
1 1/4"	009M2	17 3/8"	6"	3 1/2"	11 3/8"	14.62
1 1/2"	009	22"	7 3/4"	4 1/4"	-	30.25
1 1/2"	009M1	20 1/4"	7 3/4"	4 1/4"	-	28.25
1 1/2"	009M2	17 7/8"	6"	3 1/2"	11 3/8"	16.32
2"	009	23 3/4"	7 3/4"	4 1/4"	-	34.25
2"	009M1	21 3/8"	7 3/4"	4 1/4"	-	32.25
2"	009M2	21 3/8"	7 3/4"	4 1/2"	13 1/2"	30.00

### PRESSURE-TEMPERATURE

Series 009QT is suitable for supply pressure up to 175 PSI and water temperatures up to 140°F constant and 180°F intermittent.

### STANDARDS



USC Manual 8th Edition†

Tested and certified under the following standards for reduced pressure zone backflow preventers: ASSE No. 1013; AWWA C511-89; CSA B64.4; IAPMO Listed, File No. 1563.

† Does not indicate approval status. See below for approved models.

### AIR GAPS

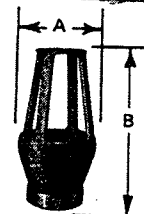

Part No	Model	Drain Size	A	B	wt lbs
AGA	1/4-1/2" 009 3/4" 009M2/M3	1/2"	2 3/8"	3 1/8"	5/8
AGC	3/4 - 1" 009 1 1/4-1 1/2" 009M2	1"	3 1/4"	4 7/8"	1 1/2
AGF	1 1/4 - 3" 009 1 1/4-2" 009M1 2" 009M2	2"	4 3/8"	8"	3 1/4

