

WATTS 700

SIZE

3/4", 1", 1 1/2", 2", 2 1/2", 3", 4"

DESCRIPTION

This is a double check assembly. It was produced approximately from 1973 to 1985. It is an in-line modular check design. Check seats were replaceable. Springs were contained when the assembly was disassembled but had to be released for proper repair. The 3/4"-2" size assembly had to be removed from the piping to be repaired.

BASIC REPAIR KIT

Repair kit contains all rubber discs, gasket, and O-rings

<u>SIZE</u>	<u>KIT NO</u>
3/4"	1BFPRK ◆
1"	2BFPRK ◆
1 1/2"	3BFPRK ◆
2"	3BFPRK ◆
2 1/2"	7BFPRK
3"	7BFPRK
4"	8BFPRK ◆

IMPORTANT FEATURES

- ~Replaceable seats
- ~Contained spring
- ~3/4"-2" not in-line repairable



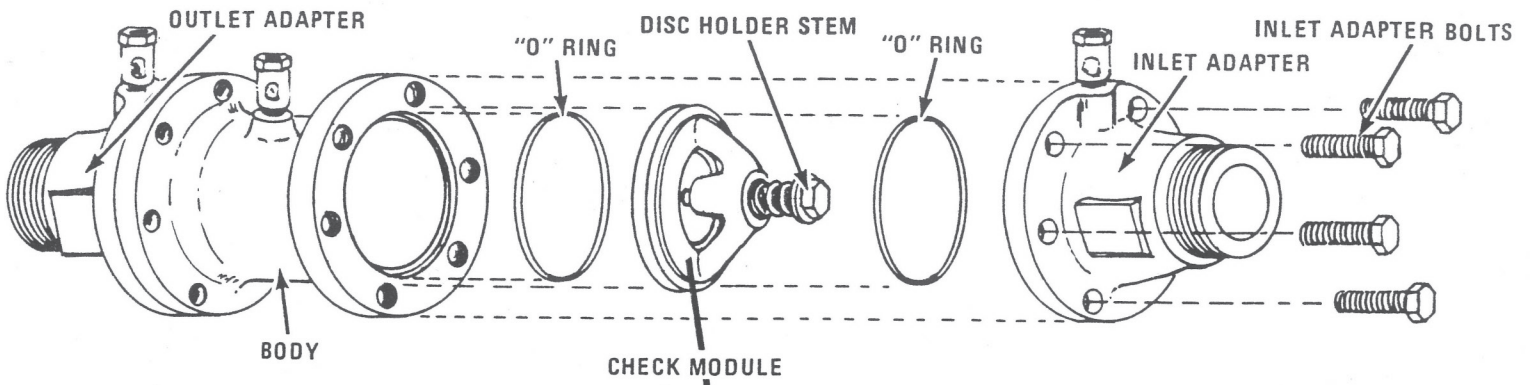

Sizes - 3/4" thru 2"

Series 700 DOUBLE CHECK VALVE ASSEMBLY

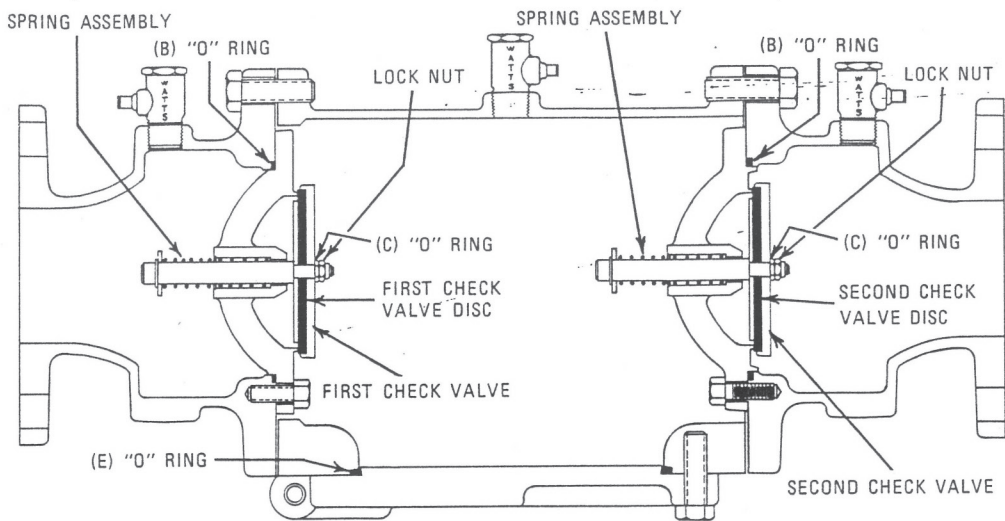

2 1/2" - 4"

